

# **POWERMATIC®**

## **Operating Instructions and Parts Manual 8-inch Parallelogram Jointer Model PJ-882, PJ882T, PJ-882HH and PJ-882HHT**



**Powermatic**  
427 New Sanford Road  
LaVergne, TN 37086  
Ph.: 800-274-6848  
[www.powermatic.com](http://www.powermatic.com)

**Part No. M-1610079**  
Edition 12 04/2023  
Copyright © 2022 Powermatic

# Warranty and Service

Powermatic warrants every product it sells against manufacturers' defects. If one of our tools needs service or repair, please contact Technical Service by calling 1-800-274-6846, 8AM to 5PM CST, Monday through Friday.

## Warranty Period

The general warranty lasts for the time period specified in the literature included with your product or on the official Powermatic branded website.

- Powermatic products carry a limited warranty which varies in duration based upon the product. (See chart below)
- Accessories carry a limited warranty of one year from the date of receipt.
- Consumable items are defined as expendable parts or accessories expected to become inoperable within a reasonable amount of use and are covered by a 90 day limited warranty against manufacturer's defects.

## Who is Covered

This warranty covers only the initial purchaser of the product from the date of delivery.

## What is Covered

This warranty covers any defects in workmanship or materials subject to the limitations stated below. This warranty does not cover failures due directly or indirectly to misuse, abuse, negligence or accidents, normal wear-and-tear, improper repair, alterations or lack of maintenance. Powermatic woodworking machinery is designed to be used with Wood. Use of these machines in the processing of metal, plastics, or other materials outside recommended guidelines may void the warranty. The exceptions are acrylics and other natural items that are made specifically for wood turning.

## Warranty Limitations

Woodworking products with a Five Year Warranty that are used for commercial or industrial purposes default to a Two Year Warranty. Please contact Technical Service at 1-800-274-6846 for further clarification.

## How to Get Technical Support

Please contact Technical Service by calling 1-800-274-6846. **Please note that you will be asked to provide proof of initial purchase when calling.** If a product requires further inspection, the Technical Service representative will explain and assist with any additional action needed. Powermatic has Authorized Service Centers located throughout the United States. For the name of an Authorized Service Center in your area call 1-800-274-6846 or use the Service Center Locator on the Powermatic website.

## More Information

Powermatic is constantly adding new products. For complete, up-to-date product information, check with your local distributor or visit the Powermatic website.

## How State Law Applies

This warranty gives you specific legal rights, subject to applicable state law.

## Limitations on This Warranty

POWERMATIC LIMITS ALL IMPLIED WARRANTIES TO THE PERIOD OF THE LIMITED WARRANTY FOR EACH PRODUCT. EXCEPT AS STATED HEREIN, ANY IMPLIED WARRANTIES OF MERCHANTABILITY AND FITNESS FOR A PARTICULAR PURPOSE ARE EXCLUDED. SOME STATES DO NOT ALLOW LIMITATIONS ON HOW LONG AN IMPLIED WARRANTY LASTS, SO THE ABOVE LIMITATION MAY NOT APPLY TO YOU.

POWERMATIC SHALL IN NO EVENT BE LIABLE FOR DEATH, INJURIES TO PERSONS OR PROPERTY, OR FOR INCIDENTAL, CONTINGENT, SPECIAL, OR CONSEQUENTIAL DAMAGES ARISING FROM THE USE OF OUR PRODUCTS. SOME STATES DO NOT ALLOW THE EXCLUSION OR LIMITATION OF INCIDENTAL OR CONSEQUENTIAL DAMAGES, SO THE ABOVE LIMITATION OR EXCLUSION MAY NOT APPLY TO YOU.

Powermatic sells through distributors only. The specifications listed in Powermatic printed materials and on the official Powermatic website are given as general information and are not binding. Powermatic reserves the right to effect at any time, without prior notice, those alterations to parts, fittings, and accessory equipment which they may deem necessary for any reason whatsoever.

## Product Listing with Warranty Period

|   |
|---|
| 90 Days – Parts; Consumable items   |
| 1 Year – Motors, Machine Accessories                                      |
| 2 Year – Woodworking Machinery used for industrial or commercial purposes |
| 5 Year – Woodworking Machinery  |

NOTE: Powermatic is a division of JPW Industries, Inc. References in this document to Powermatic also apply to JPW Industries, Inc., or any of its successors in interest to the Powermatic brand.

# Table of Contents

|   |    |
|---|----|
| Warranty and Service .....  | 2  |
| Table of Contents.....  | 3  |
| Warning.....  | 4  |
| Introduction .....  | 6  |
| Description .....   | 6  |
| Specifications .....  | 6  |
| Unpacking .....   | 7  |
| Contents of the Shipping Container .....                                | 7  |
| Installation and Assembly .....   | 8  |
| Installing Switch Arm.....  | 9  |
| Installing Cutterhead Guard .....                                       | 9  |
| Dust Collection .....   | 10 |
| Grounding Instructions.....   | 10 |
| Extension cords.....  | 11 |
| 230 Volt, Single Phase Operation .....                                  | 11 |
| Adjustments .....   | 12 |
| Drive Belt Tension.....   | 12 |
| Drive Belt Replacement .....  | 12 |
| Fence Movement .....  | 13 |
| Fence Stops .....   | 14 |
| Fence Removal .....   | 15 |
| Locking Handles.....  | 15 |
| Table and Knife Adjustments .....                                       | 15 |
| Setting Tables Coplanar.....  | 16 |
| Setting Knives at Correct Height and Parallel To Outfeed Table .....    | 18 |
| Outfeed Table Stop Screws .....   | 21 |
| Setting Infeed Table (Depth of Cut) .....                               | 21 |
| Infeed Table Depth Stop .....   | 21 |
| Infeed Table Stop Screws .....  | 21 |
| Replacing Knives (Straight Cutterhead Only) .....                       | 22 |
| Replacing or Rotating Knife Inserts (Helical Cutterhead Only) .....     | 23 |
| Eliminating “Play” in Tables.....                                       | 23 |
| Operating Controls.....   | 24 |
| Start/Stop .....  | 24 |
| Safety Key.....   | 24 |
| Hand Placement.....   | 25 |
| Surfacing .....   | 25 |
| Edge Jointing .....   | 25 |
| Rabbeting.....  | 25 |
| Jointing Short or Thin Work.....  | 26 |
| Jointing Warped Surfaces.....   | 26 |
| Beveling .....  | 26 |
| Direction of Grain .....  | 26 |
| Skewing (Shear Cutting) .....   | 26 |
| Maintenance .....   | 27 |
| Sharpening Standard Knives .....  | 28 |
| Cutterhead Repairs .....  | 28 |
| Operation .....   | 24 |
| Optional Accessories .....  | 31 |
| Replacement Parts .....   | 31 |
| Parts List: Stand Assembly .....  | 32 |
| Stand Assembly .....  | 34 |
| Parts List: Cutterhead Assembly (Model PJ-882 & PJ882T only).....       | 35 |
| Parts List: Cutterhead Assembly (Model PJ-882HH & PJ-882HHT only) ..... | 36 |
| Parts List: Fence Assembly.....   | 37 |
| Fence Assembly.....   | 38 |
| Parts List: Outfeed Table and Base Assembly.....                        | 39 |
| Outfeed Table and Base Assembly.....                                    | 40 |
| Parts List: Infeed Table Assembly.....                                  | 41 |
| Electrical Connections – 1 Phase, 230 Volt .....                        | 43 |

# Warnings

1. Read and understand the entire owner's manual before attempting assembly or operation.
2. Read and understand the warnings posted on the machine and in this manual. Failure to comply with all of these warnings may cause serious injury.
3. Replace the warning labels if they become obscured or removed.
4. This jointer is designed and intended for use by properly trained and experienced personnel only. If you are not familiar with the proper and safe operation of a jointer, do not use until proper training and knowledge have been obtained.
5. Do not use this jointer for other than its intended use. If used for other purposes, Powermatic disclaims any real or implied warranty and holds itself harmless from any injury that may result from that use.
6. Models PJ882T and PJ-882HHT have an industrial-grade low-friction corrosion-resistant coating on infeed and outfeed tables, fence, and rabbeting ledge. While this coating is durable, it can be damaged if metal or other hard and/or sharp objects strike, gouge, or scratch the surface. Significant damage to the coating may affect its performance.
7. Always wear approved safety glasses/face shields while using this jointer. Everyday eyeglasses only have impact resistant lenses; they are not safety glasses.
8. Before operating this jointer, remove tie, rings, watches and other jewelry, and roll sleeves up past the elbows. Remove all loose clothing and confine long hair. Non-slip footwear or anti-skid floor strips are recommended. Do **not** wear gloves.
9. Wear ear protectors (plugs or muffs) during extended periods of operation.
10. Do not operate this machine while tired or under the influence of drugs, alcohol or any medication.
11. Make certain the switch is in the **OFF** position before connecting the machine to the power supply.
12. Make certain the machine is properly grounded.
13. Make all machine adjustments or maintenance with the machine unplugged from the power source.
14. Remove adjusting keys and wrenches. Form a habit of checking to see that keys and adjusting wrenches are removed from the machine before turning it on.
15. Keep safety guards in place at all times when the machine is in use. If removed for maintenance purposes, use extreme caution and replace the guards immediately.
16. Check damaged parts. Before further use of the machine, a guard or other part that is damaged should be carefully checked to determine that it will operate properly and perform its intended function. Check for alignment of moving parts, binding of moving parts, breakage of parts, mounting and any other conditions that may affect its operation. A guard or other part that is damaged should be properly repaired or replaced.
17. Provide for adequate space surrounding work area and non-glare, overhead lighting.
18. Keep the floor around the machine clean and free of scrap material, oil and grease.
19. Keep visitors a safe distance from the work area. **Keep children away.**
20. Make your workshop child proof with padlocks, master switches or by removing starter keys.
21. Give your work undivided attention. Looking around, carrying on a conversation and "horse-play" are careless acts that can result in serious injury.
22. Maintain a balanced stance at all times so that you do not fall or lean against the knives or other moving parts. Do not overreach or use excessive force to perform any machine operation.
23. Use the right tool at the correct speed and feed rate. Do not force a tool or attachment to do a job for which it was not designed. The right tool will do the job better and safer.
24. Use recommended accessories; improper accessories may be hazardous.
25. Maintain tools with care. Keep knives sharp and clean for the best and safest performance. Follow instructions for lubricating and changing accessories.

26. Turn off the machine before cleaning. Use a brush or compressed air to remove chips or debris — do not use your hands.
27. Do not stand on the machine. Serious injury could occur if the machine tips over.
28. Never leave the machine running unattended. Turn the power off and do not leave the machine until it comes to a complete stop.
29. Remove loose items and unnecessary work pieces from the area before starting the machine.
30. When working a piece of wood on the jointer, follow the 3-inch rule: The hands must never be closer than 3 inches to the cutterhead at any time.
31. Always use a hold-down or push block when surfacing stock.
32. Do not joint material shorter than 10", narrower than 3/4" or less than 1/4" thick.
33. Do not make cuts deeper than 3/4" when rabbeting. On other cuts such as edging, surfacing, etc., depth of cut should not be over 1/16" to avoid overloading the machine and to minimize chance of kickback.
34. Never apply pressure to stock directly over the cutterhead. This may result in the stock tipping into the cutterhead along with the operator's fingers. Never back the workpiece toward the infeed table.
35. Don't use in dangerous environment, don't use jointer in damp or wet locations, or expose it to rain. Keep work area well lighted.
36. Always keep cutterhead and drive guards in place and in proper operation.
37. Always use hold-down/push blocks for jointing material narrower than 3 inches, or thinner than 3 inches.
38. Maintain the proper relationships of infeed and outfeed table surfaces and cutterhead knife path.
39. Support the workpiece adequately at all times during operation; maintain control of the work at all times.
40. Don't back the work toward the infeed table.

**Familiarize yourself with the following safety notices used in this manual:**



This means that if precautions are not heeded, it may result in minor injury and/or possible machine damage.



This means that if precautions are not heeded, it may result in serious injury or possibly even death.

**- - SAVE THESE INSTRUCTIONS - -**

## Introduction

This manual is provided by Powermatic covering the safe operation and maintenance procedures for Powermatic Model PJ-882, PJ882T, PJ-882HH, and PJ-882HHT Jointers. This manual contains instructions on installation, safety precautions, general operating procedures, maintenance instructions and parts breakdown. This machine has been designed and constructed to provide consistent, long-term operation if used in accordance with instructions set forth in this manual. If there are any questions or comments, please contact either your local supplier or Powermatic. Powermatic can also be reached at our web site: [www.Powermatic.com](http://www.Powermatic.com).

## Description

The PJ-882 family of jointers is built upon a parallelogram design. This design allows independent adjustment of sections of the infeed and outfeed tables to ensure the tables remain parallel with the cutterhead and with each other. The fence has a tilting capacity of 45 degrees forward and backward, with positive stops.

## Specifications

|   |                               |                                |
|---|-------------------------------|--------------------------------|
| Model Number / Stock Number.....              | PJ-882 / 1610079 .....        | PJ-882HH / 1610082 .....       |
| Model Number / Stock Number.....              | PJ882T / PM1-1610079T .....   | PJ-882HHT / PM1-1610082T ..... |
| Motor .....                                   | 2HP, 1Ph, 230V .....          | 2HP, 1Ph, 230V .....           |
| Maximum Cutting Width (in.).....              | 8 .....                       | 8 .....                        |
| Maximum Cutting Depth (in.) .....             | 1/2 .....                     | 1/2 .....                      |
| Rabbeting Capacity (in.) .....                | 1/2 .....                     | not applicable .....           |
| Cutterhead Speed (RPM) .....                  | 7,000 .....                   | 7,000 .....                    |
| Starter .....                                 | magnetic .....                | magnetic .....                 |
| Knives .....                                  | 3 standard .....              | 54 four-sided inserts .....    |
| Knife size (L x W x T).....                   | 8 x 11/16 x 1/8 in. ....      | 15 x 15 x 2.5 mm .....         |
| Number of Cutterhead Rows .....               | --- .....                     | 6 .....                        |
| Cuts Per Minute .....                         | 21,000 .....                  | not applicable .....           |
| Cutterhead Diameter (in.) .....               | 3-1/16 .....                  | 3-1/16 .....                   |
| Table Surface (L x W)(in.).....               | 83 x 8 .....                  | 83 x 8 .....                   |
| Fence Size (L x H)(in.).....                  | 38 x 4-3/4 .....              | 38 x 4-3/4 .....               |
| Fence Tilt (deg.).....                        | 45 forward, 45 backward ..... | 45 forward, 45 backward .....  |
| Positive Stops (deg.).....                    | -45, 90, +45 .....            | -45, 90, +45 .....             |
| Dust Chute Diameter (in.) .....               | 4 .....                       | 4 .....                        |
| Dust Collection Required Capacity (CFM) ..... | 450 .....                     | 450 .....                      |
| Overall Dimensions (L x W x H)(in.).....      | 84 x 28 x 44 .....            | 84 x 28 x 44 .....             |
| Net Weight – approx. (lbs.) .....             | 610 .....                     | 610 .....                      |
| Shipping Weight – approx. (lbs.).....         | 744 .....                     | 744 .....                      |

The above specifications were current at the time this manual was published, but because of our policy of continuous improvement, Powermatic reserves the right to change specifications at any time and without prior notice, without incurring obligations.

# Unpacking

**⚠WARNING** Read and understand all instructions before attempting assembly or operation of band saw. Failure to comply may cause serious injury.

**⚠CAUTION** Models PJ882T and PJ-882HHT have an industrial-grade low-friction corrosion-resistant coating on infeed and outfeed tables, fence, and rabbeting ledge. While the coating is durable, it can be damaged if metal or other hard and/or sharp objects strike, gouge, or scratch the surface. Significant damage to the coating may affect its performance. Use care when unpacking and locating the machine and during all setup and assembly procedures.

Open shipping container and check for shipping damage. Report any damage immediately to your distributor and shipping agent. Do not discard any shipping material until the Jointer is assembled and running properly.

Compare the contents of your container with the following parts list to make sure all parts are intact. Missing parts, if any, should be reported

to your distributor. Read the instruction manual thoroughly for assembly, maintenance and safety instructions.

## Contents of the Shipping Container

- 1 Jointer
- 1 Cutterhead guard
- 2 Push blocks
- 1 8mm/10mm Open-end wrench (*PJ-882 & PJ882T only*)
- 1 3mm Hex wrench (*PJ-882 & PJ882T only*)
- 1 4mm Hex wrench
- 1 5mm Hex wrench
- 1 Owner's Manual
- 1 Warranty Card
- 1 Aluminum knife gauge (*PJ-882 & PJ882T only*)
- 2 Star point screwdrivers (*PJ-882HH & PJ-882HHT only*)
- 10 Knife insert screws (*PJ-882HH & PJ-882HHT only*)
- 5 Knife inserts (*PJ-882HH & PJ-882HHT only*)

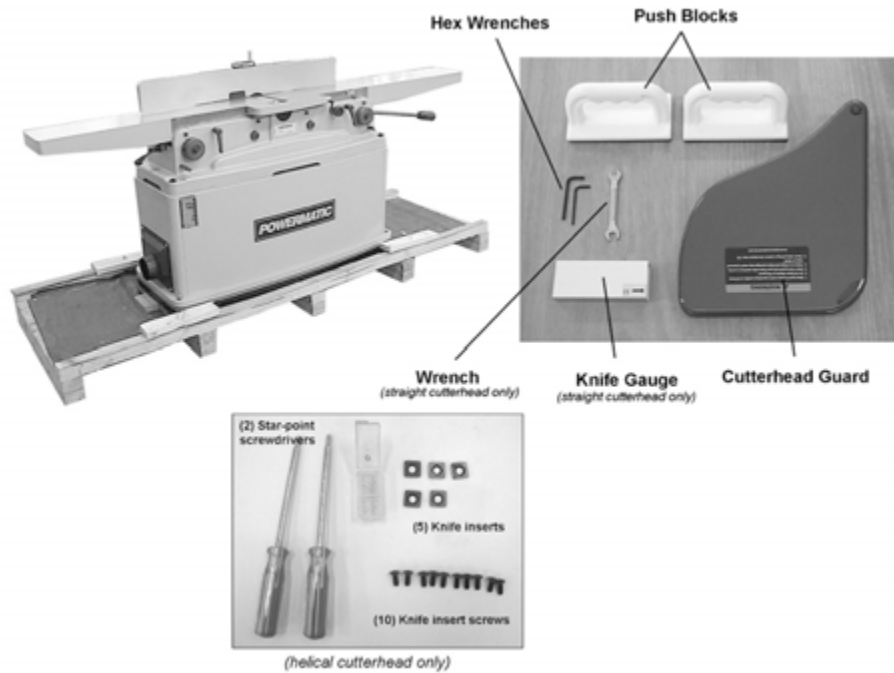

**⚠WARNING** Read and understand the entire contents of this manual before attempting set-up or operation! Failure to comply may cause serious injury.

# Installation and Assembly

## Tools Required for Assembly

Forklift or hoist with straps/slings  
14mm (or 9/16") wrench or socket  
Cross-point (Phillips) screwdriver  
3mm and 5mm hex wrenches (provided)

1. Remove any boards or straps that secure the Jointer to the pallet and remove protective wrapping.
2. Use a 14mm (or 9/16") wrench to remove the four lag screws at the base of the stand which helped secure the machine to the pallet. One of these screws is shown in Figure 1.



Figure 1

**CAUTION** The Jointer should be raised by straps placed around the four lifting rods (see Figure 2). Do NOT lift the machine directly beneath the infeed and outfeed tables, as this can cause misalignment of the tables.

3. Pull the four lifting rods out as far as they will go and run the straps around the rods as shown in Figure 2. Using a forklift or hoist, lift the machine off the pallet and into its desired location. When the straps are removed, push the lifting rods back in.
4. The Jointer should be located in a dry area, on a sturdy floor, and with sufficient lighting and ventilation. Leave plenty of space around the machine for operations and routine maintenance work.
5. If desired, the Jointer can be further stabilized by securing it to the floor, using lag screws through the four holes at the base of the stand.

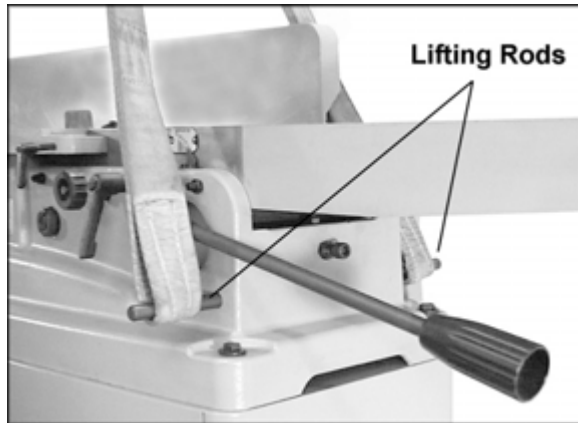

Figure 2  
(straps not included)

**WARNING** The jointer should be disconnected from the power source during assembly procedures.

6. Exposed metal areas of the Jointer, such as the table and fence surfaces, have been factory coated with a protectant. This can be removed with a soft cloth dampened with kerosene or mineral spirits. Do not use an abrasive pad. Do not let solvent contact plastic or rubber parts as it may damage them. **Note: Models PJ882T and PJ-882HHT have an industrial-grade low-friction corrosion-resistant coating and will not require cleaning with solvents.**

**WARNING** Use caution when cleaning around cutterhead. The knives are extremely sharp.



## Installing Switch Arm

1. The switch arm was shipped in horizontal position. Loosen and remove the four socket head cap screws and flat washers on the bracket of the switch arm (Figure 3) with a 5mm hex wrench. Hold on to the switch arm while doing this, to prevent the arm from falling.
2. Place the switch arm in vertical position, as shown in Figure 3, and align the four holes in the bracket with the four holes in the jointer stand.
3. Re-insert the four socket head cap screws with the four flat washers, as shown in Figure 3.
4. Firmly tighten the four socket head cap screws with the hex wrench.

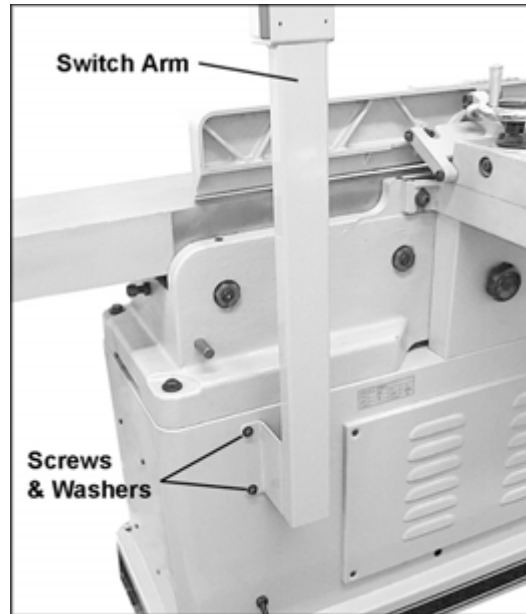

Figure 3

## Installing Cutterhead Guard

**⚠WARNING** Jointer knives are extremely sharp. Use caution when working with or around the cutterhead.

The cutterhead guard has a spring tension mechanism which must be properly tensioned when installing the cutterhead guard on the machine.

To install the cutterhead guard:

1. Insert a small hex wrench, or similar object, into the pin on the guard tension mechanism (Figure 4).
2. Twist the hex wrench and pin clockwise, as shown in Figure 5, and hold them there.
3. Lower the shaft of the guard into the hole on the jointer's rabbeting ledge. See Figure 6. The guard should be lowered into the hole far enough that the groove in the guard's shaft will align with the set screw (Figure 6).
4. After the guard has been inserted into the hole, let go of the guard with your left hand - the guard will swing toward the fence.
5. Completely tighten the set screw (Figure 6), while continuing to hold the hex wrench and pin with your right hand.
6. When the guard is secured, remove the hex wrench from the pin. Slightly loosen the set screw (Figure 6) until the pin snaps back against the rabbeting ledge.
7. Re-tighten the set screw (Figure 6).

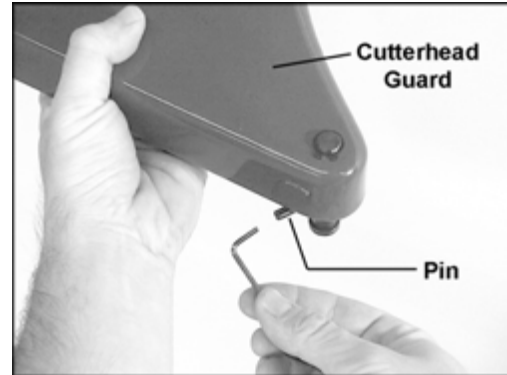

Figure 4



Figure 5

The cutterhead guard should now have sufficient spring tension. Test it by swinging the guard away from the fence and then releasing it.

**⚠WARNING** The guard must always have enough spring tension to cover the unused part of the cutterhead during the cutting operation, and to swing back to contact the fence when the workpiece has cleared the area.

If more spring tension on the guard is desired, follow the above procedure with this exception: tighten the set screw without allowing the pin to snap back to the rabbeting ledge. The farther clockwise the pin is situated, the greater will be the spring tension.

### Dust Collection

It is strongly recommended that a dust collection system (not provided) be connected to the jointer. It will help keep your shop clean and reduce the risk of health problems due to wood dust. The dust collector should have sufficient capacity for this size jointer.

Connect the dust collection hose to the 4" diameter dust port on the jointer (Figure 7) and secure it with a hose clamp.

NOTE: Dryer vent hose is not acceptable for this purpose.

### Grounding Instructions

**⚠WARNING** Electrical connections must be made by a qualified electrician in compliance with all relevant codes. This machine must be properly grounded to help prevent electrical shock and possible fatal injury.

This machine should be connected to a grounded metal permanent wiring system; or to a system having an equipment-grounding conductor. In the event of a malfunction or breakdown, grounding provides a path of least resistance for electric current to reduce the risk of electric shock.

Improper connection of the equipment-grounding conductor can result in a risk of electric shock. The conductor with insulation having an outer surface that is green with or without yellow stripes, is the equipment-grounding conductor. If repair or replacement of the electric cord or plug is necessary, do not connect the equipment-grounding conductor to a live terminal.

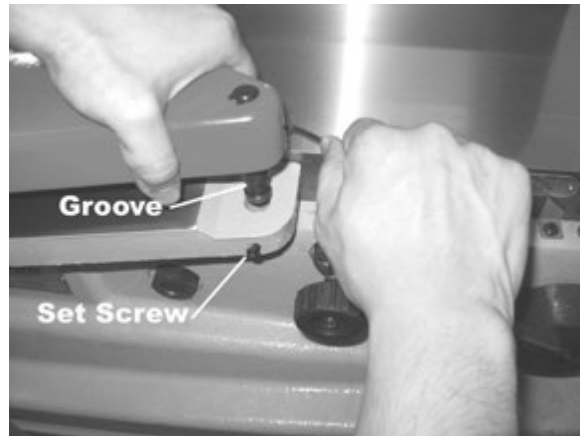

Figure 6

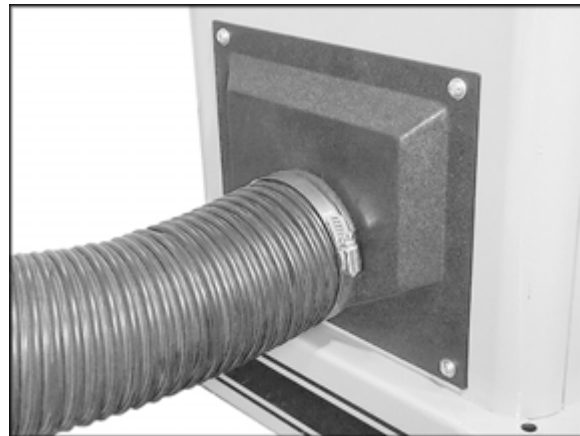

Figure 7  
(hose and clamp not provided)

Check with a qualified electrician or service personnel if the grounding instructions are not completely understood, or if in doubt as to whether the tool is properly grounded.

Use only three wire extension cords that have three-prong grounding plugs and three-pole receptacles that accept the tool's plug.

Repair or replace a damaged or worn cord immediately.

Make sure the voltage of your power supply matches the specifications on the motor plate of the Jointer.

### Extension cords

The use of an extension cord is not recommended for this Jointer. But if one is necessary, make sure the cord rating is suitable for the amperage listed on the machine's motor plate. An undersized cord will cause a drop in line voltage resulting in loss of power and overheating.

Use the chart in Figure 8 as a general guide in choosing the correct size cord. If in doubt, use the next heavier gauge. The smaller the gauge number, the heavier the cord.

### 230 Volt, Single-Phase Operation

As received from the factory, the **single-phase** model of this Jointer is designed to run on 230-volt power only.

The jointer has a grounding plug that looks like the plug illustrated in Figure 9; or you may choose to "hard-wire" the machine directly to a control panel. If hard-wired to a panel, make sure a disconnect is available for the operator. The Jointer must comply with all local and national codes after being wired.

If the Jointer is to be hard-wired, make sure the fuses have been removed or the breakers have been tripped in the circuit to which the Jointer will be connected. Place a warning placard on the fuse holder/circuit breaker to prevent it being turned on while the machine is being wired.

The Jointer with a 230-volt plug should only be connected to an outlet having the same configuration. No adapter is available or should be used with the 230-volt plug.

It is recommended that the **single-phase** jointer be connected to a dedicated, *minimum* 20-amp circuit with a 20-amp circuit breaker or time delay fuse. **Local codes take precedence over recommendations.**

**Recommended Gauges (AWG) of Extension Cords**

| Amps     | Extension Cord Length * |         |         |          |          |          |
|----------|-------------------------|---------|---------|----------|----------|----------|
|          | 25 feet                 | 50 feet | 75 feet | 100 feet | 150 feet | 200 feet |
| < 5      | 16                      | 16      | 16      | 14       | 12       | 12       |
| 5 to 8   | 16                      | 16      | 14      | 12       | 10       | NR       |
| 8 to 12  | 14                      | 14      | 12      | 10       | NR       | NR       |
| 12 to 15 | 12                      | 12      | 10      | 10       | NR       | NR       |
| 15 to 20 | 10                      | 10      | 10      | NR       | NR       | NR       |
| 21 to 30 | 10                      | NR      | NR      | NR       | NR       | NR       |

\*based on limiting the line voltage drop to 5V at 150% of the rated amperes.

NR: Not Recommended.

Figure 8

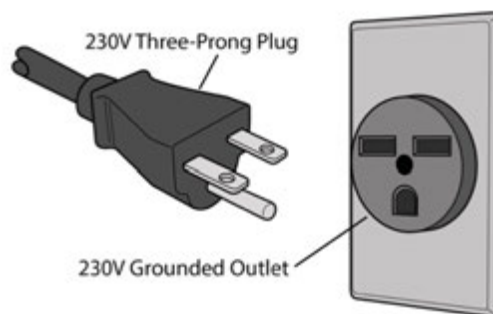

Figure 9

## Adjustments

**CAUTION** Models PJ882T and PJ-882HHT have an industrial-grade low-friction corrosion-resistant coating on infeed and outfeed tables, fence, and rabbeting ledge. While the coating is durable, it can be damaged if metal or other hard and/or sharp objects strike, gouge, or scratch the surface. Significant damage to the coating may affect its performance. Use care when making adjustments to this machine.

### Drive Belt Tension

To check or adjust the drive belt tension:

1. Unscrew the knob (A, Figure 11) and remove the belt guard (B, Figure 11).
2. Remove the rear panel (C, Figure 11) by unscrewing the four flat head screws (D, Figure 11) with a cross-point screwdriver.
3. Proper drive belt tension is achieved when there is a small amount of deflection in the drive belt midway between the pulleys, when using moderate finger pressure (Figure 12).
4. To increase the tension on the drive belt, loosen the lower hex nut (B, Figure 13) with a 17mm wrench, and tighten the top hex nut (A, Figure 13). When finished, tighten lower hex nut (B, Figure 13).
5. Re-install rear panel and belt guard.

NOTE: After operating the machine for a short time, the drive belt tension should be re-checked, as the new drive belt may stretch slightly during the “breaking-in” period.

### Drive Belt Replacement

1. Unscrew the knob (A, Figure 11) and remove the belt guard (B, Figure 11).
2. Remove the rear panel (C, Figure 11) by removing the four flat head screws with a cross-point screwdriver.
3. On the motor base plate, loosen the top hex nut (A, Figure 13) and lift the motor to create slack in the drive belt. Remove the drive belt from both pulleys.
4. Install the new drive belt around top and bottom pulleys, and tension it appropriately (see “Drive Belt Tension”).
5. Re-install rear panel and belt guard (Figure 11).

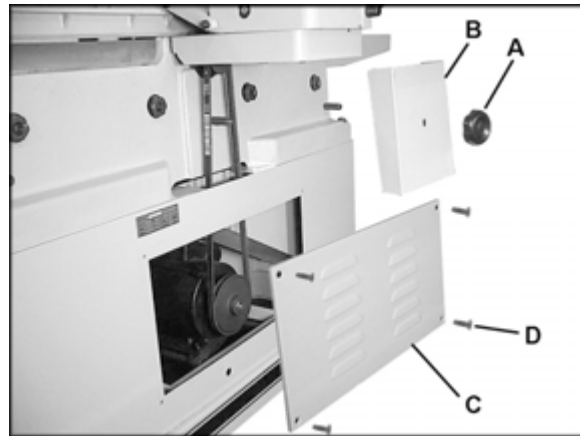

Figure 11

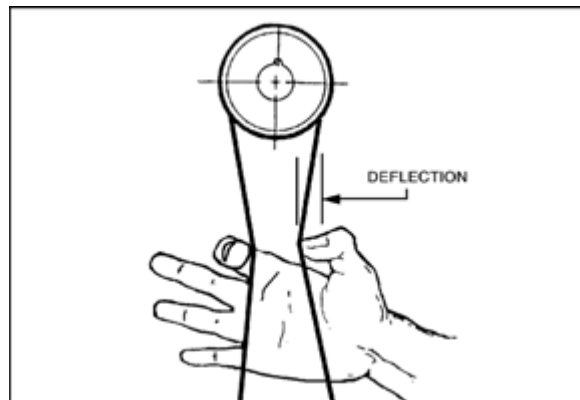

Figure 12

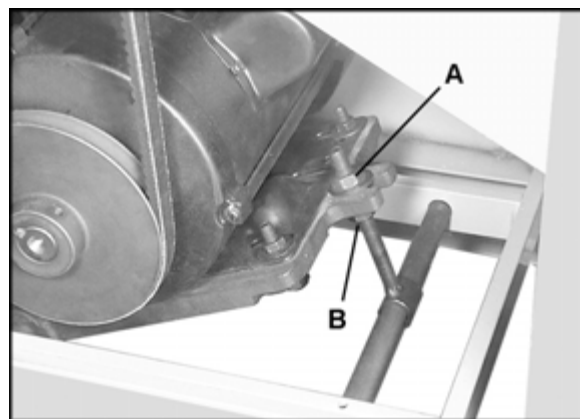

Figure 13

## Fence Movement

The fence can be moved forward or backward across the width of the table. It also tilts up to 45 degrees forward and backward, and contains positive stops at both these angles, as well as a positive stop at 90 degrees.

### To Slide Fence Forward or Backward:

1. Loosen locking handle (A, Figure 14).
2. Push the entire fence assembly to the desired position, and tighten locking handle (A, Figure 14). A plastic buffer piece is mounted to the front of the fence to prevent scratching the table when moving the fence.

**NOTE:** If the lock handle (A, Figure 14) is in an inconvenient position, it can be adjusted. Loosen the two hex nuts underneath the slide bracket (Figure 15). Flip the handle to the desired position and re-tighten the hex nuts. Do not over-tighten the hex nuts, as this can make the fence difficult to move on the slide bracket.

### To Tilt Fence Forward:

The fence can be tilted forward to any angle down to 45 degrees.

1. Loosen locking handle (B, Figure 14).
2. Rotate handwheel (C, Figure 14) until the desired angle is indicated on the scale (D, Figure 14). Or you can place your beveled workpiece on the table and against the fence, and rotate the handwheel (C, Figure 14) until the angle of the fence matches the bevel of your workpiece.
3. Tighten locking handle (B, Figure 14).

### To Tilt Fence Backward:

The fence can be tilted backward up to 45° (that is, for a total angle of 135° from table surface).

1. Loosen locking handle (B, Figure 16).
2. Flip the 90° stop block (E, Figure 16) out of the way.
3. Rotate handwheel (C, Figure 16) until the desired angle is indicated on the scale (D, Figure 16). Or you can place your beveled workpiece on the table and against the fence, and rotate the handwheel (C, Figure 16) until the angle of the fence matches the bevel of your workpiece.
4. Tighten locking handle (B, Figure 16).

**IMPORTANT:** When the tilted operation is finished and the fence is returned to 90°, do not forget to flip the 90° stop block (F, Figure 16) back to its original position.

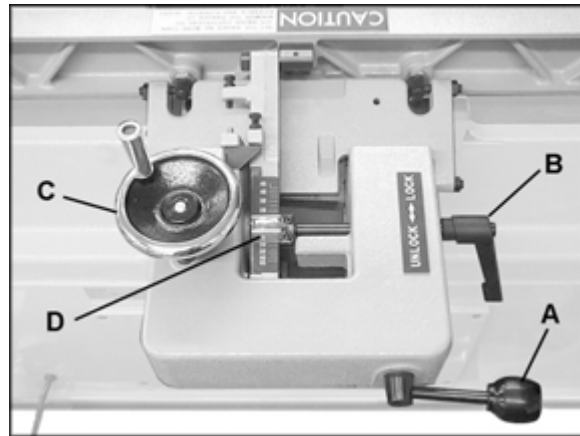

Figure 14

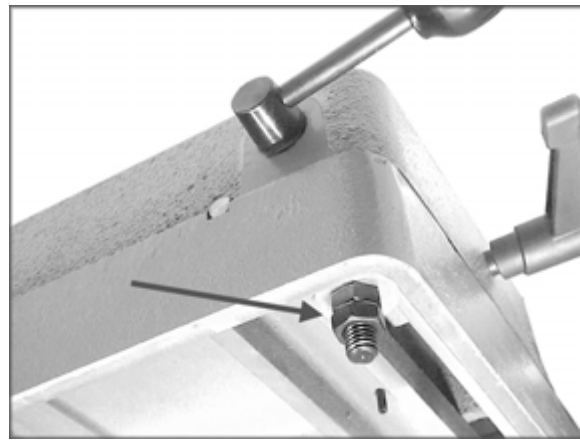

Figure 15

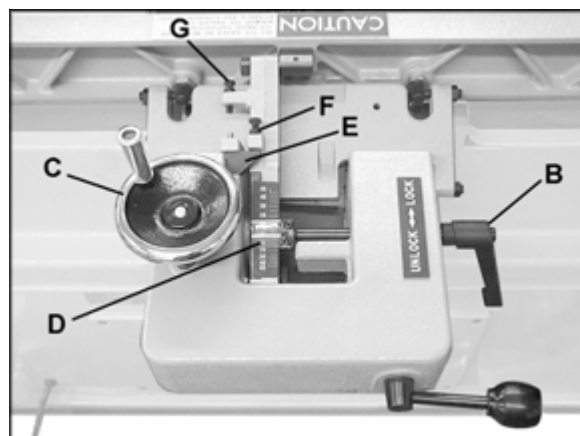

Figure 16

## Fence Stops

Periodically check the 90° and 45° tilt accuracy of the fence with an angle measuring device, such as an adjustable square or machinist's protractor. If adjustments are necessary, proceed as follows:

### Setting the 90° Stop

1. The 90° stop is controlled by the screw (F, Figure 16) and the stop block (E, Figure 16).
2. Loosen the locking handle (B, Figure 16) and loosen the hex nut on the screw (F, Figure 16).
3. Set your angle measuring device to 90 degrees and place it on the table and against the fence.
4. Move the fence until it fits flush against the angle measuring device. Turn the screw (F, Figure 16) until the screw contacts the stop block (E, Figure 16).
5. Tighten the hex nut on the screw (F, Figure 16) and the lock handle (B, Figure 16).

### Setting the 45° Forward Stop

1. The 45° forward stop is controlled by the screw (H, Figure 17).
2. Loosen the locking handle (B, Figure 16) and loosen the hex nut on the screw (H, Figure 17).
3. Set your angle measuring device at 45°. Place it on the table and against the fence and tilt the fence until it is flush against the 45° angle.
4. Rotate the screw (H, Figure 17) until it contacts the casting in front of it.
5. Tighten the hex nut on the screw (H, Figure 17) and tighten locking handle (B, Figure 16).

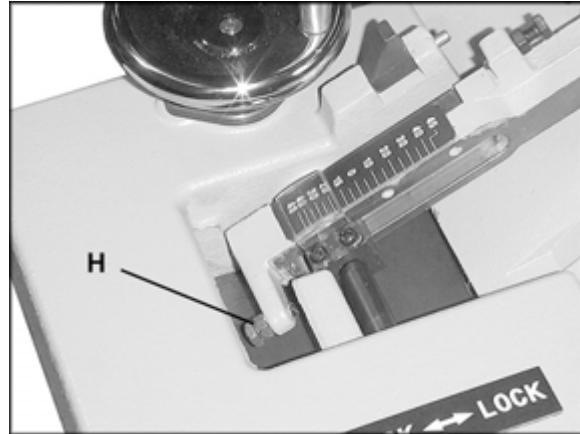

Figure 17

### Setting the 45° Backward Stop

1. The 45° backward stop is controlled by the screw (G, Figure 18), which will contact the back of the fence when the fence is tilted backward.
2. Flip the stop block (E, Figure 18) out of the way.
3. Loosen the locking handle (B, Figure 18) and loosen the hex nut on the screw (G, Figure 18).
4. Tilt the fence backward. Set your angle measuring device at 135° and place it on the table and against the fence.
5. If necessary, turn the screw (G, Figure 18), until the fence lies flush against the angle measuring device.
6. Re-tighten the hex nut on the screw (G, Figure 18) and tighten locking handle (B, Figure 18).

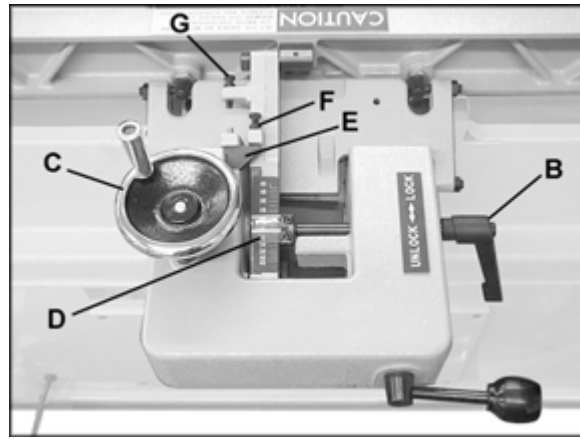

Figure 18

### Fence Removal

To remove the fence assembly from the machine, remove the two hex nuts and one flat washer that secure it to the slide bracket (see Figure 15). Lift the fence straight up and off the Joints.

When re-installing the fence assembly, make sure the cutout in the fence assembly sits over the key in the slide bracket.

### Locking Handles

All locking handles of the type shown in B, Figure 18, can be rotated if they are in the way of other machine parts. Simply lift straight out on the locking handle and rotate it, then release, making sure it seats properly.

### Table and Knife Adjustments

For accurate jointing, at least three things must be true:

1. Infeed and outfeed tables must be “coplanar”.
2. Knives or knife inserts must be set in the cutterhead so that the highest point of their arc is level with the outfeed table.
3. On the standard cutterhead, knives must be parallel with the outfeed table across the entire length of the knives.

These alignments are explained below.

## Setting Tables Coplanar

For optimum performance of the jointer, the infeed and outfeed tables must be coplanar; that is, parallel front-to-back and side-to-side. If they are not parallel in both planes, the finished workpiece may have a slight taper across its width or length.

The tables have been properly aligned at the factory. However, they should be double-checked by the operator in case any misalignment may have occurred during shipping. Also, as the machine receives use, this coplanarity should be checked occasionally and adjusted if necessary.

The following procedure uses a steel straight edge to set the tables, which should be accurate enough for most purposes.

This procedure demonstrates how to set the parallelism of the outfeed table; the procedure for the infeed table will be identical.

1. Disconnect jointer from power source.
2. Remove the cutterhead guard by loosening the set screw (see Figure 6) and lifting the guard shaft out of the hole.
3. Slide the fence assembly back as far as it will go or remove it from the machine entirely (see page 15 for instructions on removing the fence).
4. Loosen the locking handle on the outfeed table (see A, Figure 23). Use the lifting handle (B, Figure 23) to raise the outfeed table higher than the cutterhead.
5. Place a straight edge across the front of the outfeed table and extending over the infeed table. See Figure 19.
6. Raise the infeed table until it contacts the straight edge. To raise the infeed table, loosen the locking handle (see A, Figure 28) and lift the adjustment arm (B, Figure 28). When it contacts the straight edge, tighten the locking handle (A, Figure 28).
7. The straight edge should lie evenly across both tables without gaps between straight edge and table. Move the straight edge to the back of the outfeed table and perform the same test. See Figure 20.
8. If the straight edge does not lie evenly, the front or back of the table must be adjusted to make the tables coplanar. Proceed as follows.
9. Each table has four cam adjustment devices, two in front and two in back. (C, Figure 22 shows one of these).

NOTE: On the front of the Jointer, the two outside cams are concealed by the hubs.

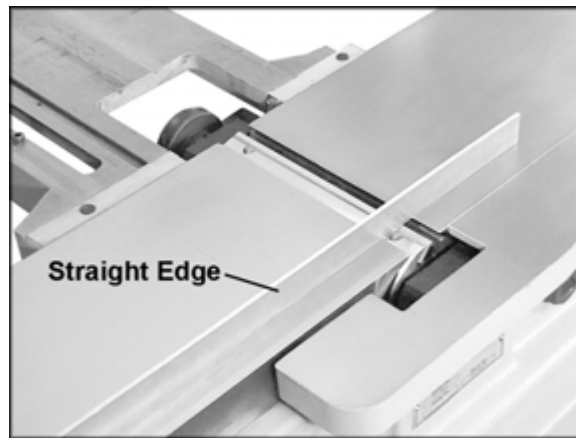

Figure 19



Figure 20



You must remove the hub to expose the cam adjustment device. Remove the socket head cap screw and flat washer at the center with a 6mm hex wrench and loosen the setscrews in the hub (Figure 21 shows one of two set screw holes). NOTE: One of the holes contains two set screws; remove the upper setscrew and loosen the lower one.

Pull the hub straight out to expose the cam adjustment device.

10. Pull the hub straight out to expose the cam adjustment device.
11. At the area of the table where the adjustment must be made, pry out the cap (A, Figure 22) from the hole.
12. There are two set screws in the hole. Insert a 4mm hex wrench (B, Figure 22) into the hole and loosen the upper set screw by turning the hex wrench counterclockwise. Remove the upper set screw from the hole.
13. Loosen the lower set screw (do not remove it) by turning counterclockwise with the hex wrench.
14. Turn the hex nut (C<sub>1</sub>, Figure 22) with a 1-1/4" wrench. **This adjustment is sensitive and should be made in small increments.** NOTE: The rotation is different for left and right hex nuts; the right hex nut (C<sub>1</sub>) being turned in Figure 22 will be turned clockwise to raise that area of the table, or counterclockwise to lower that area of the table. The left hex nut (C<sub>2</sub>) shown in Figure 22 would be rotated in the opposite manner.
15. Use the straight edge upon the tables to check the adjustment until the tables are coplanar.
16. When the adjustment is satisfactory, with the tables now coplanar, tighten the lower set screw with the hex wrench (B, Figure 22).
17. Insert and tighten the upper set screw.
18. Re-insert the cap (A, Figure 22) to keep dust and debris out of the hole.

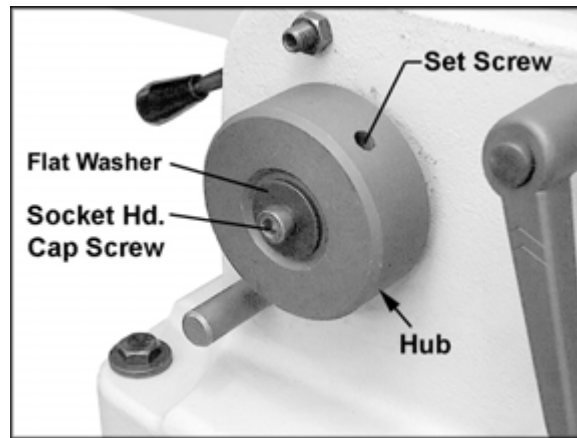

Figure 21

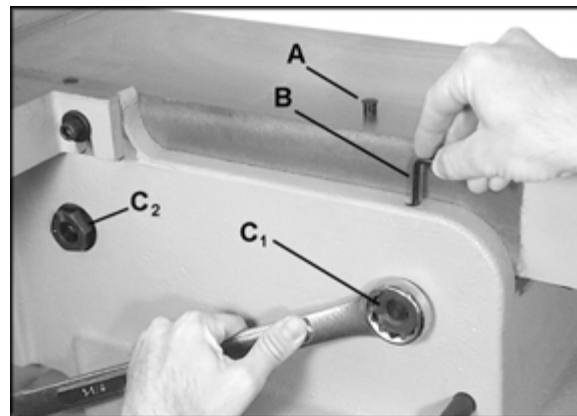

Figure 22  
(back of outfeed table shown)

## Setting Knives at Correct Height and Parallel to Outfeed Table

For accurate jointing, the outfeed table surface must be level with the knives (or knife inserts for the helical cutterhead) at the high point of their arc. In addition, on the straight cutterhead, the knives must be parallel with the outfeed table along the entire length of the knives.

When you receive the jointer, the knives have been pre-set at the factory. However, the height and parallelism of the knives with the outfeed table should be checked, and any needed adjustments made, before operating the jointer.

Height setting of knives is not applicable to the helical head models, in which the knife inserts are immediately at the proper height after installing. However, the height of the outfeed table must still be verified in relation to the arc of the knife inserts, as follows.

**⚠WARNING** Knives or knife inserts are extremely sharp; use caution and proceed slowly when setting them.

To set outfeed table in relation to the knives, proceed as follows:

1. Disconnect jointer from power source.
2. Raise the outfeed table by loosening the locking handle (A, Figure 23) and using the lever (B).
3. Place a straight edge upon the outfeed table and extending over the center of the cutterhead as shown in Figures 23 and 24.
4. Rotate the cutterhead, using the belt or pulley, until one knife or knife insert is at its highest point. **Do not** grab the cutterhead itself to rotate it.
5. Lower the outfeed table until the straight edge contacts the knife, as shown in Figure 24. Using the drive belt, rock the cutterhead slightly to make sure the apex of the knife is contacting the straight edge.
6. Lock the outfeed table at that height by tightening the locking handle (A, Figure 23).

The importance of the knives being level with the outfeed table are shown by these examples of incorrect settings:

If the outfeed table is too high, the finished surface of the workpiece will be curved. See Figure 25.

If the outfeed table is too low, the work will have a gouge, or snipe, at the end of the cut. See Figure 26.

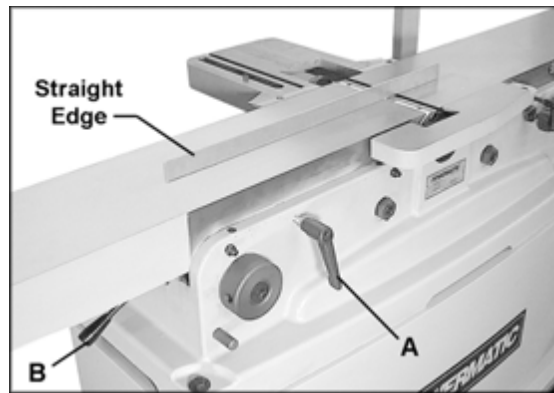

Figure 23

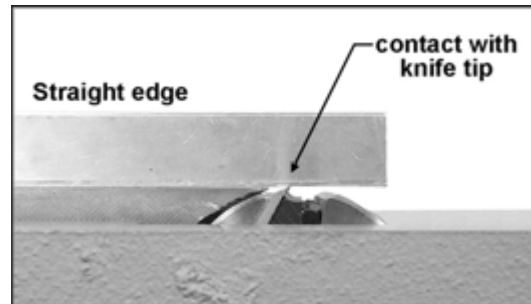

Figure 24

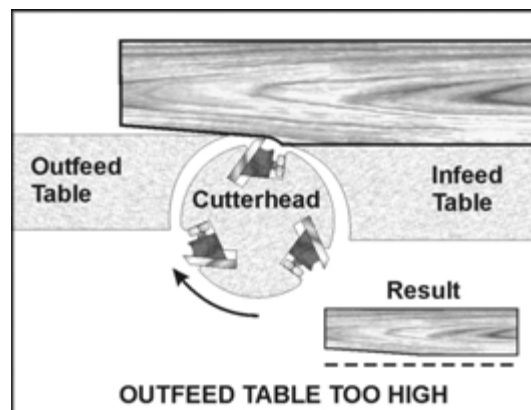

Figure 25

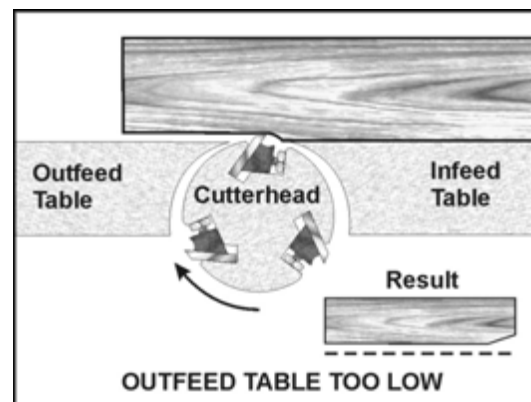

Figure 26

Figure 27 illustrates the correct setting of outfeed table level with the knives. The workpiece will rest firmly on both tables with no open space under the finished cut.

The outfeed table has now been locked at a standard height, level with the arc of the knives. NOTE: After the outfeed table has been set at the correct height, it should not be changed except for special operations or after replacing knives.

On the **helical cutterhead**, after the outfeed table has been set, no further adjustments will be needed for the knife inserts. When inserts are installed properly in the helical cutterhead, they will automatically be set at the proper position.

On the **standard cutterhead**, further fine adjustments will now be achieved by adjusting the knives in the cutterhead. Proceed as follows.

7. Lower the infeed table out of the way, by loosening the locking handle (A, Figure 28) and pushing down on the adjustment arm (B, Figure 28).
8. An aluminum knife setting gauge, shown in Figure 29, is provided with the jointer. If you require very fine tolerances when setting the knives, a knife setting gauge with a dial readout can be purchased. The provided aluminum gauge should, however, be accurate enough for most woodworking needs.
9. Place the provided knife setting gauge at the back of the outfeed table (toward the fence support side) and extending over the cutterhead as shown in Figure 29. Place the gauge so that the right mark lines up with the edge of the outfeed table, as shown.
10. Rotate the cutterhead clockwise (by using the pulley). If table and knives are set correctly, the knife will contact the aluminum gauge and move the gauge until the left mark now lines up with the edge of the outfeed table, as shown in Figure 30.
11. Place the aluminum knife gauge at the front of the outfeed table (toward the rabbet ledge) and repeat the process.
12. This test should be performed on all three knives in the cutterhead, using the provided gauge.
13. If any knife is either too high or too low at one of its ends to correctly move the gauge as described above, then the height and/or parallelism of that knife in the cutterhead needs to be adjusted. Proceed as follows.
14. Slightly loosen the five gib screws (see Figure 31) with an 8mm wrench. (NOTE:

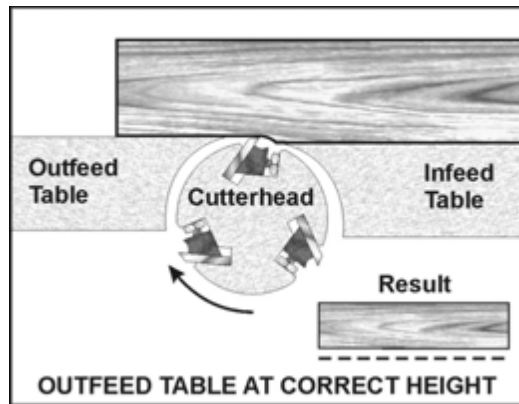

Figure 27

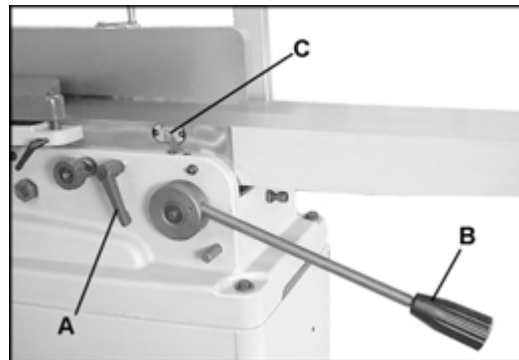

Figure 28

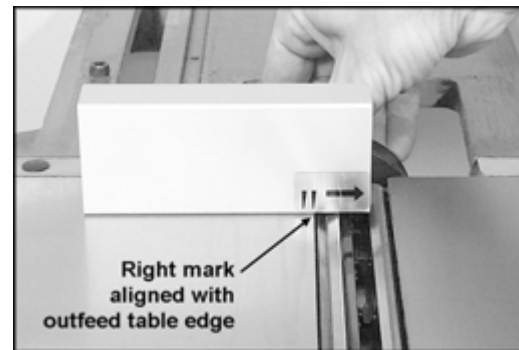

Figure 29 (straight cutterhead)

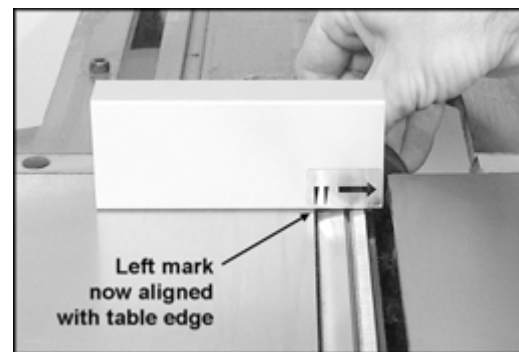

Figure 30 (straight cutterhead)

The springs below the knife will cause the knife to rise.)

15. Turn the jack screw(s) with a hex wrench; clockwise to lower the setting of the knife in the cutterhead, counterclockwise to raise the setting of the knife.
16. Use the edge of a board to push the knife back down so that it is flush against the jack screws. See Figure 32. Tighten the gib screws only enough to keep the knife in position in the cutterhead. Do not fully tighten.
17. Check the height of the knife again by using the gauge at front and back of the outfeed table. Make further adjustments to the jack screw(s) as needed.
18. Repeat this process for each of the other two knives in turn. Do not fully tighten gib screws, only tighten them enough to keep the knife in position.
19. For best results, knives should be set at approximately .015" above the cutterhead. Knife height should not vary more than .002-.003" across the length of the cutterhead. All three knives must be set at equal height in the cutterhead and parallel to the outfeed table across their length.
20. After the three (3) knives are positioned properly in the cutterhead and made snug, continue tightening the gib screws. The gib screws should be tightened in increments, to prevent any distortion to the cutterhead or buckling of knives. Begin tightening the gib screws a little more on one knife. Start with the center screw and work your way to the ends. Do not fully tighten yet.
21. Rotate the cutterhead to the other two knives in turn. Repeat step 19 for each knife.
22. The tightening process should continue at least two more times, each time tightening the gib screws further on all three knives in turn. On the third time, the gib screws should all be firmly tightened.

**⚠ WARNING** Before operating the jointer, make sure all gib screws are firmly tightened. A loose knife thrown from the cutterhead can cause severe or fatal injury.

23. After all knife adjustments are completed, the guards and fence assembly should be placed back on the machine before operating.

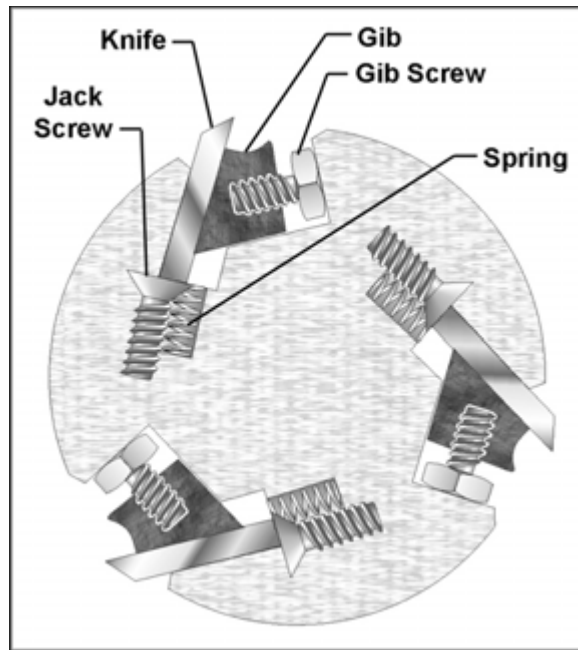

Figure 31 (straight cutterhead)

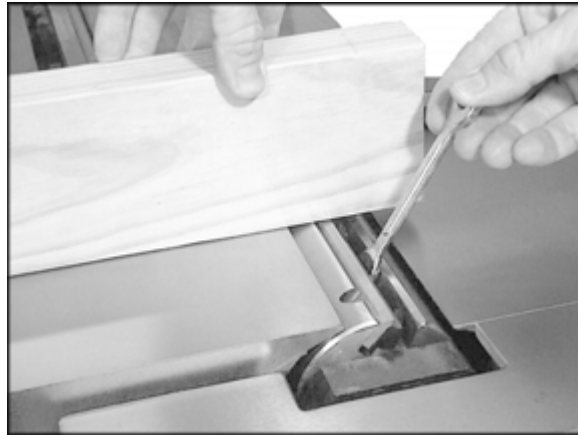

Figure 32 (straight cutterhead)

## Outfeed Table Stop Screws

The stop screw (B, Figure 33) limits the amount of fall of the outfeed table. The stop screw has been pre-set at the factory, but if future adjustment is ever needed, simply loosen the hex nut (A, Figure 33) and turn the screw (B, Figure 33) as needed with a 14mm wrench. When satisfied, re-tighten the hex nut (A, Figure 33).

The screw (C, Figure 33) limits the rise of the outfeed table. If adjustment is needed, loosen the hex nut (D, Figure 33) and turn the screw (C, Figure 33) as needed with a 9mm hex wrench. When satisfied, re-tighten the hex nut (D, Figure 33).

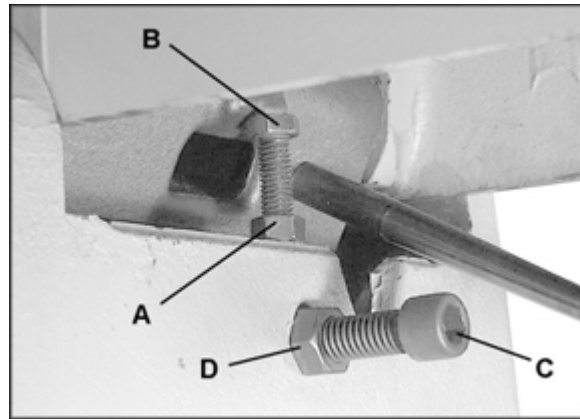

Figure 33

## Setting Infeed Table (Depth of Cut)

1. Loosen locking handle (A, Figure 34).
2. Move table adjustment arm (B, Figure 34) to raise or lower infeed table to the desired depth of cut, which is shown on the gauge via the pointer (C, Figure 34).

NOTE: Do not exceed 1/8" maximum depth of cut. For deeper cuts, make several passes.

3. Re-tighten locking handle (A, Figure 34).

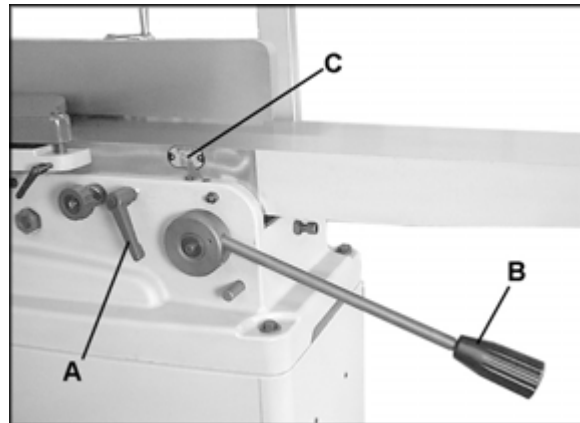

Figure 34

## Infeed Table Depth Stop

The knob (Figure 35) controls a depth stop. When the infeed table is lowered, it will stop at the 1/8" depth mark.

To further lower the infeed table, such as for rabbeting operations, disengage the depth stop by pulling out on the knob, rotating the knob 90° and then releasing it. The infeed table can then be lowered all the way.

To re-engage the depth-stop, rotate the knob 90° until the knob snaps back in.

## Infeed Table Stop Screws

The stop screws below the infeed table have the same function as those for the outfeed table. See "Outfeed Table Stop Screws" for instructions on adjustment.

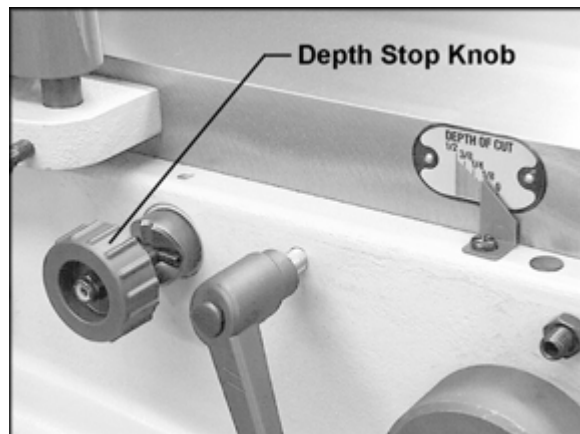

Figure 35

## Replacing Knives (Straight Cutterhead Only)

**WARNING** Jointer knives are extremely sharp. Use caution and proceed slowly when working with or around the cutterhead.

1. Disconnect jointer from power source.
2. Remove the belt guard so that you can rotate the cutterhead by turning the motor pulley or by moving the drive belt. **Do not** grab the cutterhead itself to rotate it.
3. Remove the old knives by loosening the square head gib screws with an 8mm wrench. See Figure 36. The springs in the cutterhead will raise the knife for easy removal. Remove knife and gib.
4. Clean the gib and the knife slot. Sandwich the new knife and gib together and drop into slot. Make sure the knife is oriented properly in the cutterhead, as shown in Figure 36.

**IMPORTANT:** To position the knives for rabbet cuts, take a shop scale with 1/32" graduations and place it against the end of the cutterhead. Slide the knife out until it is at the 1/32" mark on the scale; that is, the knife will now be 1/32" beyond the edge of the cutterhead. The gib should remain in normal position, even with the edge of the cutterhead. See Figure 37. This adjustment will ensure that the knife clears the end of the gib and cutterhead and has good contact with the workpiece. (See the "Operation" section for further information on rabbeting procedures.)

(NOTE: This same procedure can be used if a small nick develops in the knives; simply stagger the knives in the cutterhead to remove the effect of the nick, without having to replace the knives.)

5. The height and parallelism of the knife in the slot, both for rabbeting and normal jointer work, must now be set properly, to ensure correct operation as well as minimize the hazard of kickback. Refer to "Setting Knives at Correct Height and Parallel to Outfeed Table" on pages 18-20 for information on adjustment and tightening procedures for the knives.

**WARNING** Before starting the jointer, make sure all gib screws are firmly tightened. A loose knife thrown from the cutterhead can cause severe or fatal injury.

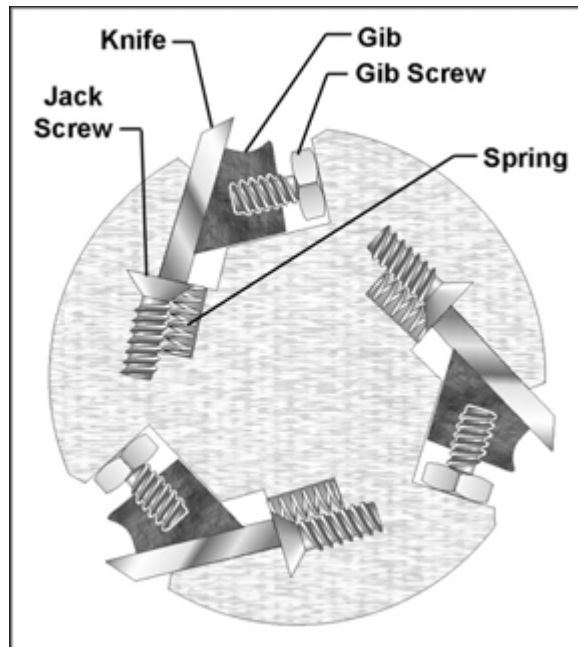

Figure 36 (straight cutterhead)

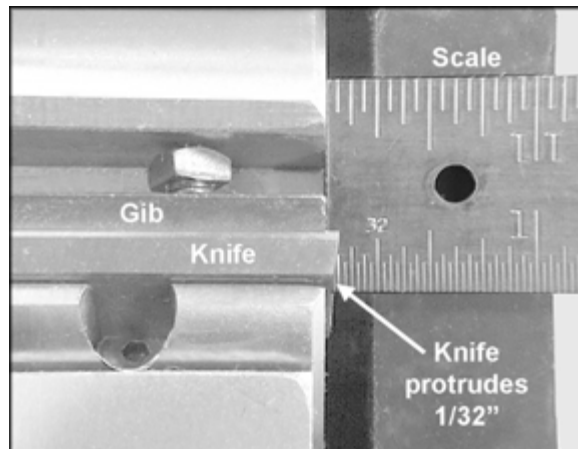

Figure 37 (straight cutterhead)

## Replacing or Rotating Knife Inserts (Helical Cutterhead Only)

**⚠WARNING** Knife inserts are sharp; use caution when working with or around them.

The knife inserts on the model PJ-882HH and PJ-882HHT are four-sided. When dull, simply remove each insert, rotate it 90° for a fresh edge, and re-install it.

Use the provided star point screwdriver to remove the knife insert screw. See Figure 37a. It is advisable to rotate all inserts at the same time to maintain consistent cutting. However, if one or more knife inserts develop a nick, rotate only those inserts that are affected.

Each knife insert has an etched reference mark so you can keep track of the rotations.

**IMPORTANT:** When removing or rotating inserts, clean saw dust from the screw, the insert, and the cutterhead platform. Dust accumulation between these elements can prevent the insert from seating properly and may affect the quality of the cut.

Before installing each screw, lightly coat screw threads with machine oil and wipe off excess.

Securely tighten each screw which holds the knife inserts before operating the planer!

**⚠WARNING** Make sure all knife insert screws are tightened securely. Loose inserts can be propelled at high speed from a rotating cutterhead, causing injury.

Make sure the outfeed table is set level with the knife inserts (follow steps 1 thru 6 on page 18).

## Eliminating “Play” in Tables

There are four set screws at the front of the jointer – two on the outfeed table and two on the infeed table – that will allow you to prevent “play” in the tables. (Figure 38 shows one of the set screws for the outfeed table.)

After a period of use, the copper tip (see item #27, page 41) which is attached to the end of the set screw (A, Figure 38) may become loose. Resolve this as follows.

1. Loosen the hex nut (B, Figure 38) with a 14mm wrench.
2. Tighten the set screw (A, Figure 38) with a 5mm hex wrench. Do not overtighten the set screw, as it may prevent the table from being raised and lowered easily.
3. Tighten hex nut (B, Figure 38).
4. Repeat for the other set screws as needed.

NOTE: The outfeed table is pre-set at the factory tighter than the infeed table. If you find

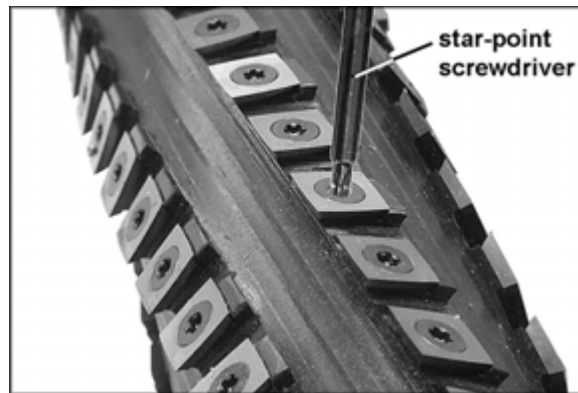

Figure 37a  
(helical cutterhead only)

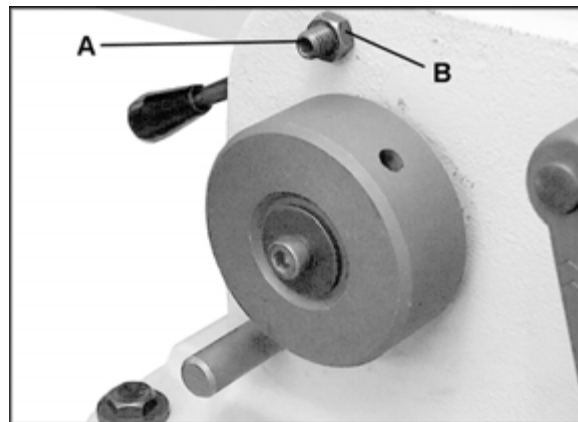

Figure 38

the outfeed table difficult to move with the lifting handle, loosen the two set screws on the outfeed table, as just described.

## Operating Controls

### Start/Stop

**Power Indicator Light** – The *start switch* has a power indicator lamp which is *on whenever there is power connected* to the Jointer, not just when the Jointer is running. *Do not assume that no light means there is no power to the machine.* If the bulb is bad, there will be no indication. Always check before use.

**⚠WARNING** Do not rely on that no light means no power to the machine. Always check for power first. Failure to comply may cause serious injury!

Referring to Figure 39:

**Start** – Press the green start switch.

When power is connected to the machine, the green light is always on regardless of whether the Jointer is running or not.

**Stop** – Press the red switch to stop.

**Reset** – In the event that the Jointer stops without pressing the stop button, as the result of a tripped fuse or circuit breaker, etc.:

Press red button to reset on main switch.

Press the green button to restart the machine.

### Safety Key

The start/stop switch on the Jointer comes equipped with a magnetic safety key. When in place on the switch as shown in Figure 39, the magnetic safety key trips a relay which will allow the machine to start and stop when the respective switches are pressed. Being magnetic, the lock can be removed to make the machine inoperable and can be hidden for safe storage by attaching it to another magnetic surface.

When using the Jointer, place the key on the switch cover lining up the arrow on the key with the REMOVE arrow on the cover. Then rotate the key so that the arrow lines up with the LOCK arrow. This will prevent the safety key from coming loose from vibration when the machine is in use.

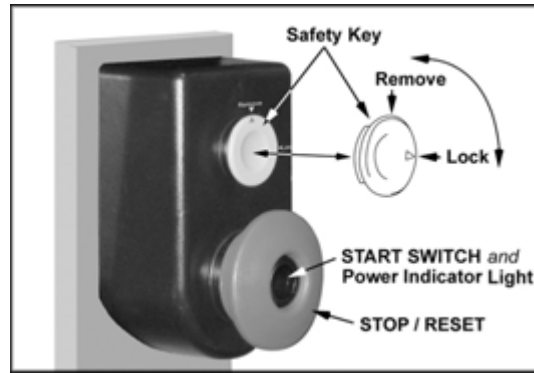

Figure 39

## Operation

**⚠CAUTION** Models PJ882T and PJ-882HHT have an industrial-grade low-friction corrosion-resistant coating on infeed and outfeed tables, fence, and rabbeting ledge. While the coating is durable, it can be damaged if metal or other hard and/or sharp objects strike, gouge, or scratch the surface. Significant damage to the coating may affect its performance. Use care when operating the machine.

NOTE: If you are inexperienced at jointing, use scrap pieces of lumber to check settings and get the feel of operations before attempting regular work.

Stabilize long workpieces by using an assistant, or roller stands set level with the outfeed or infeed table surface.

The fence should be adjusted to create minimum exposure to the cutterhead during the jointing operation.

Check the following before operating the jointer:

1. Outfeed table must be set level with the high point of the knives or knife inserts.
2. Fence adjusted for minimum exposure of cutterhead and locked at desired angle.
3. The cutterhead guard must be in place and operating properly (except when rabbeting).
4. Infeed table set for desired depth of cut.
5. Stand away from the cutterhead and turn the machine on for a few moments. Listen for any odd noises, rubbings, vibrations, etc. Identify and correct such problems before attempting operations on the jointer.
6. Carefully check your workpiece for knots, holes, staples or any foreign material that might damage knives or pose a risk of kickback. Also check the workpiece for grain orientation (see "Direction of Grain" on page 26).



## Hand Placement

At the start of the cut, the left hand holds the workpiece firmly against the infeed table and fence while the right hand pushes the workpiece in a smooth, even motion toward the cutterhead. After the cut is under way, the new surface rests firmly on the outfeed table. The left hand is transferred to the outfeed side and presses down on this part of the workpiece, at the same time maintaining flat contact with the fence. The right hand presses the workpiece forward and before the right hand reaches the cutterhead it should be moved to the work on the outfeed table. **Never pass hands directly over the cutterhead.**



Figure 40

## Surfacing

**⚠WARNING** Always use a hold down or push block when surfacing stock.

Jointing the face of stock, or surfacing, is shown in Figure 40. Adjust the infeed table for depth of cut. Cuts of approximately 1/16" at a time are recommended, as this allows better control over the material being surfaced. More passes can then be made to reach the desired depth.



Figure 41

## Edge Jointing

This is the most common operation for the jointer. Set fence square with the table. Depth of cut should be the minimum required to obtain a straight edge. Do not make cuts deeper than 1/8" in a single pass. Hold the best face of the workpiece firmly against the fence throughout the feed. See Figure 41.

## Rabbeting

**⚠WARNING** A rabbet cut requires removal of the guard. Use extreme caution and keep hands clear of cutterhead. Always re-install guard immediately after rabbeting operation is completed.

A rabbet is a groove cut along the edge of a board. See Figure 42. The width and thickness of the wood to be rabbeted depends upon the width and length of the rabbet. However, never rabbet a piece of wood less than 12" long.

Use push blocks to rabbet cut whenever possible. The rabbeting capacity is 1/2".

1. Disconnect jointer from power source.
2. Set fence for desired width of rabbet.
3. Check width of the rabbet by measuring the distance from the end of a knife in the cutterhead to the fence.

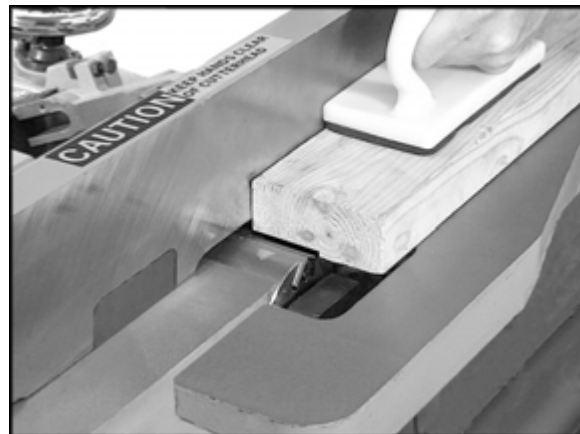

Figure 42

**IMPORTANT:** Rabbeting can be done with the straight knife cutterhead only; it is not applicable with the helical cutterhead model.

NOTE: The knives must be extended beyond the cutterhead by 1/32". (see "Replacing Knives – Straight Cutterhead Only" on page 22 for this procedure).

4. Re-connect power. It is easier and safer to take a series of shallow cuts. Lower the infeed table 1/32" at a time and make successive cuts until the desired depth of rabbet has been obtained. See Figure 42.

### Jointing Short or Thin Work

When jointing short or thin work pieces, use a push block to eliminate all danger to the hands. Two push blocks are shipped with your jointer. You can also make your own easily from scrap material. Examples are shown in Figure 43.

### Jointing Warped Surfaces

If the wood to be jointed is cupped or bowed, place the concave side down, and take light cuts until the surface is flat.

Avoid forcing such material down against the table – excessive pressure will spring it while passing the knives, and it will spring back and remain curved after the cut is completed.

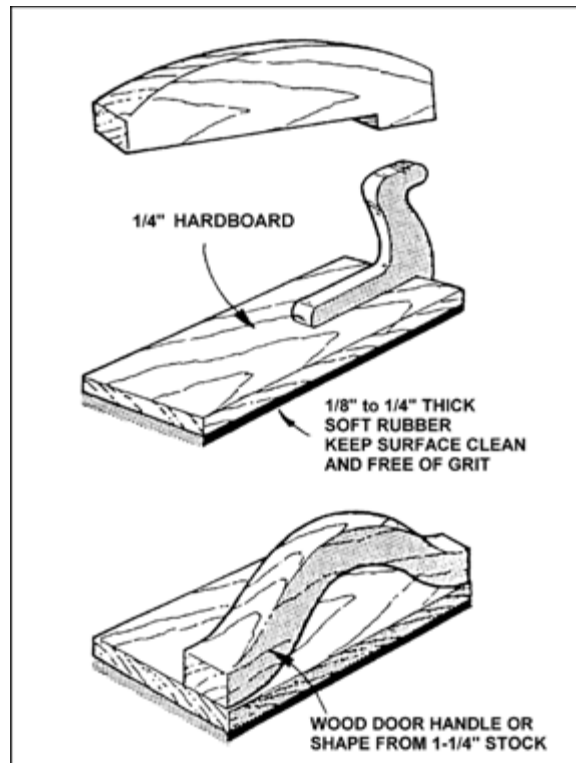

Figure 43

### Beveling

To cut a bevel, lock the fence at the required angle and run the work piece across the knives while keeping it firmly against the fence and tables. Several passes may be necessary to achieve the desired result.

**CAUTION** Although the fence may be tilted in or out for a bevel cut, it is recommended for safety reasons that the fence be tilted in toward the operator, making a cradled cut.

### Direction of Grain

Avoid feeding work into the jointer against the grain. This may result in chipped and splintered edges. See Figure 44. Feed *with* the grain to obtain a smooth surface, as shown in Figure 45.

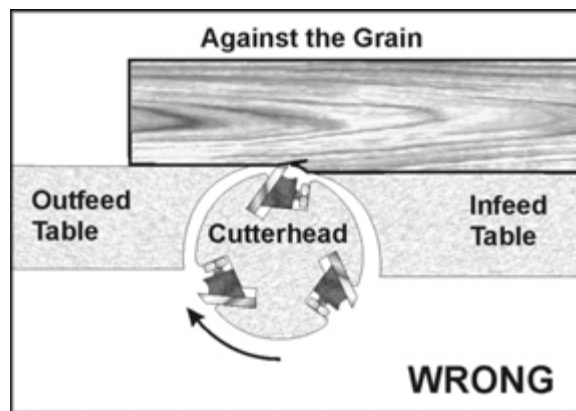

Figure 44

### Skewing (Shear Cutting)

When edging or facing material such as burl or birds-eye maple, it is not unusual to deface or mar the surface being finished. This is caused by the cutterhead knives at times cutting against the grain. In order to prevent the defacing or marring of this type of wood, it is necessary to skew the material being worked so that it crosses the knives at an angle.

The fence will allow for this type of cut:

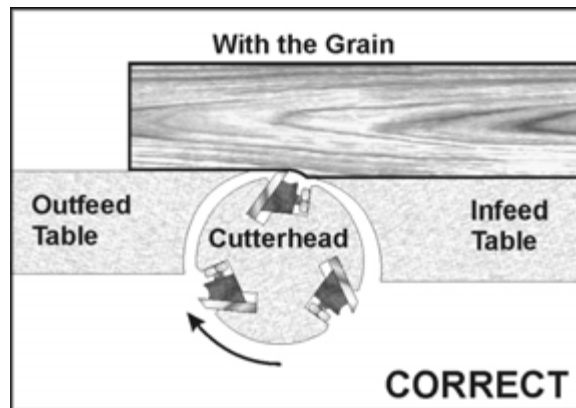

Figure 45

1. Release the fence locking handle (A, Figure 46) and remove the two hex nuts and washer (B, Figure 46) holding the fence to the slide bracket. Remove the fence assembly.
2. Remove the key (C, Figure 46) from the fence support. If necessary, use a flat head screwdriver to pry up one end of the key.
3. Replace the fence assembly at the desired angle across the cutterhead. See Figure 47. Secure the fence to the slide bracket with the hex nuts and washer (B, Figure 46), then tighten the fence locking handle (A, Figure 46).

NOTE: When placing the fence assembly back into normal position, be sure to first install the key (C, Figure 46) into its slot.

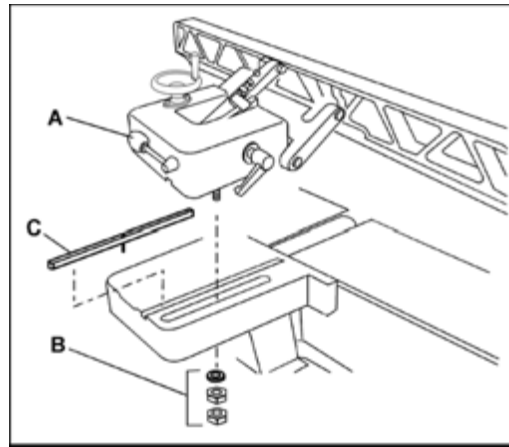

Figure 46

## Maintenance

**⚠WARNING** Disconnect machine from power source before doing any maintenance. Failure to comply may cause serious injury.

**⚠CAUTION** Models PJ882T and PJ-882HHT have an industrial-grade low-friction corrosion-resistant coating on infeed and outfeed tables, fence, and rabbeting ledge. While the coating is durable, it can be damaged if metal or other hard and/or sharp objects strike, gouge, or scratch the surface. Significant damage to the coating may affect its performance. Use care when performing maintenance on this machine.

**For model PJ-882 & PJ-882HH:** The table and fence surfaces must be kept clean and free of rust for best results. Some users apply a thin coat of paste wax. Avoid waxes or protective sprays that contain silicone, as this can transfer to the workpiece and make it difficult for later finishes to adhere to the wood.

**For model PJ-882 & PJ-882HH:** Another option is talcum powder applied with a blackboard eraser rubbed in vigorously once a week; this will fill casting pores and form a moisture barrier. This method provides a tabletop that is slick and allows rust rings to be easily wiped from the surface. Important also is the fact that talcum powder will not stain wood or mar finishes as some other products.

Gum and pitch which collect on the knives cause excessive friction as the work continues, resulting in overheating of the knives, less efficient cutting, and consequent reduction in the life of the knives. Use oven cleaner or “gum and pitch remover” to wipe this off the knives. **Use caution when working around knives!**



Figure 47  
(skewing the fence)

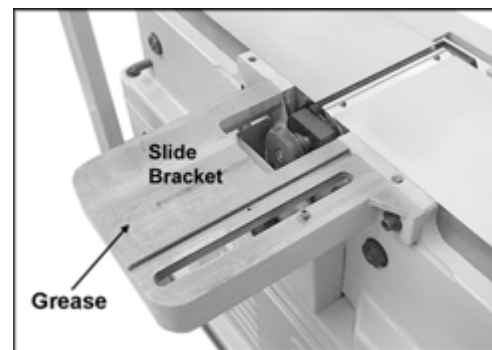

Figure 48



Figure 49

The bearings in the cutterhead are sealed for life and do not require lubrication.

The fence assembly should slide easily over the slide bracket. Keep the slide bracket, shown in Figure 48, lubricated with a good quality multi-purpose grease. Do not get grease on the drive belt.

Do not place heavy objects on the tables or use the jointer as a storage table.

### Sharpening Standard Knives

Knives should be kept sharp. This will contribute to better stock finish, longer machine life, and safer operation.

A jointer knife hone provides a simple way to sharpen knives. Hones are available from many woodworking supply stores. Carefully read any instructions that accompany the hone.

**WARNING** Use caution and proceed slowly when sharpening knives. Disconnect jointer from power source and wear approved eye protection.

When finished sharpening knives, they should be re-set level with and parallel to the outfeed table. See "Setting Knives at Correct Height and Parallel to Outfeed Table" on page 18.

Knives can usually be whetted several times in the cutterhead before having to be removed and re-ground.

**TIP:** If the jointer is used frequently, keeping a spare set of knives on hand is recommended. Extra knives (stock no. 6296046, set of 3) may be obtained from your distributor, or by calling customer service at 1-800-274-6848.

### Cutterhead Repairs

The entire cutterhead assembly may be removed from the Jointer for bearing replacement or other maintenance procedures.

**WARNING** Use caution when working around sharp knives.

To remove the cutterhead, proceed as follows:

1. Disconnect jointer from power source.
2. Remove fence assembly from jointer.
3. Lower both infeed and outfeed table.
4. Remove belt guard and remove drive belt from around cutterhead pulley.
5. Remove knives from cutterhead.
6. Remove rabbeting ledge by loosening and removing the two hex cap screws and washers which secure it to the infeed table.
7. Loosen the two bolts that secure the cutterhead to the base; these are accessed through the gap below the jointer base. See Figures 49 and 50. Place a wrench on each of the bolt heads and turn each bolt until the cutterhead is loosened.
8. Lift cutterhead straight up from base.
9. Remove pulley and both bearing housings.

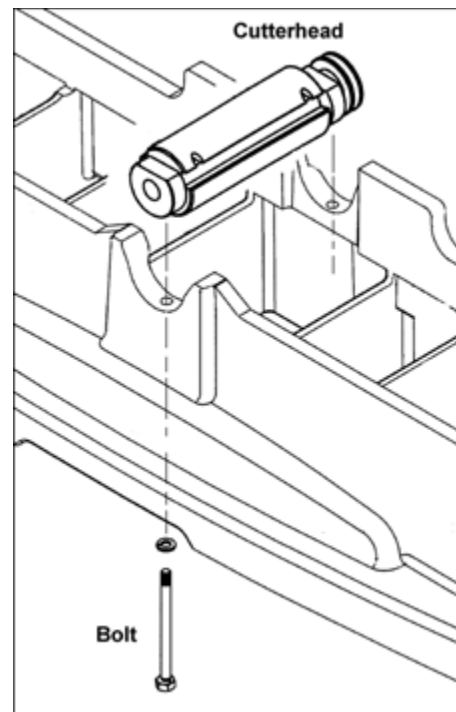

Figure 50

**IMPORTANT:** If the bearings need replacement, this should be done by qualified service personnel. Bearings are press fitted and must be removed or installed with an arbor press.

10. To re-install cutterhead, reverse the above procedure. Before re-installing, make sure the machine's curved seats of the base casting are free of dirt, dust or grease, to help ensure a tight fit.
11. After the cutterhead has been installed, check the infeed and outfeed table settings in relationship to the cutterhead.

**TIP:** You may wish to keep an extra cutterhead on hand to maintain shop productivity.

## Troubleshooting – Operating Problems

| <b>Trouble</b>                                       | <b>Probable Cause</b>   | <b>Remedy</b>  |
|--|---|--|
| Finished stock is concave on back end.               | Knife or knife insert is higher than outfeed table.                       | Raise outfeed table until it aligns with tip of knife/insert. See page 18.   |
| Finished stock is concave on front end.              | Outfeed table is higher than knife or insert.                             | Lower outfeed table until it aligns with tip of knife/insert. See page 18.   |
| Finished stock is concave in the middle.             | Both tables have too much end fall.                                       | Raise both table ends using the cam adjustment devices. See pages 16-17.   |
| Ends of finished stock are cut more than the middle. | Table ends are raised higher than the middle.                             | Lower both table ends using the cam adjustment devices. See pages 16-17.   |
| Chip out.  | Cutting against the grain.  | Cut with the grain whenever possible.  |
|  | Dull knives or knife inserts.   | Sharpen or replace knives.<br>Rotate or replace knife inserts.   |
|  | Feeding workpiece too fast.   | Use slower rate of feed.   |
|  | Cutting too deeply.   | Make shallower cuts.   |
|  | Knots, imperfections in wood.   | Inspect wood closely for imperfections; use different stock if necessary.  |
| Fuzzy grain.   | Wood has high moisture content.   | Allow wood to dry or use different stock.  |
|  | Dull knives or knife inserts.   | Sharpen or replace knives.<br>Rotate or replace knife inserts.   |
| Cutterhead slows while operating.                    | Feeding workpiece too quickly or applying too much pressure to workpiece. | Feed more slowly or apply less pressure to workpiece.  |
| Chatter marks on workpiece (standard cutterhead).    | Knives incorrectly set.   | Set knives properly using provided knife setting gauge. Check that knife slots are clean and free of dust or debris. |
|  | Feeding workpiece too fast.   | Feed workpiece slowly and consistently.  |
| Uneven knife marks on workpiece.                     | Knives or knife inserts are nicked or out of alignment.                   | Replace nicked knives or rotate inserts; align standard knives properly using knife-setting gauge. See pages 18-23.  |

## Troubleshooting – Mechanical and Electrical Problems

| Trouble  | Probable Cause                                | Remedy   |
|--|---|--|
| Machine will not start/restart or repeatedly trips circuit breaker or blows fuses. | No incoming power.                            | Verify unit is connected to power, on-button is pushed in completely, and stop-button is disengaged. See page 24.  |
|  | Overload automatic reset has not reset.       | When jointer overloads on the circuit breaker built into the motor starter, it takes time for the machine to cool down before restart. Allow unit to adequately cool before attempting restart. If problem persists, check amp setting on the motor starter inside the electrical enclosure.   |
|  | Jointer frequently trips.                     | One cause of overloading trips which are not electrical in nature is too heavy a cut. The solution is to take a lighter cut. If too deep a cut is not the problem, then check the amp setting on the overload relay. Match the full load amps on the motor as noted on the motor plate. If amp setting is correct, then there is probably a loose electrical lead. Check amp setting on motor starter.   |
|  | Building circuit breaker trips or fuse blows. | Verify that jointer is on a circuit of correct size. If circuit size is correct, there is probably a loose electrical lead. Check amp setting on motor starter.  |
|  | Switch or motor failure (how to distinguish). | If you have access to a voltmeter, you can separate a starter failure from a motor failure by first, verifying incoming voltage at 220+/-20 and second, checking the voltage between starter and motor at 220+/-20. If incoming voltage is incorrect, you have a power supply problem. If voltage between starter and motor is incorrect, you have a starter problem. If voltage between starter and motor is correct, you have a motor problem. |
|  | Motor overheated.                             | Clean motor of dust or debris to allow proper air circulation. Allow motor to cool down before restarting.   |
|  | Motor failure.                                | If electric motor is suspect, you have two options: Have a qualified electrician test the motor for function or remove the motor and take it to a qualified electric motor repair shop and have it tested.   |

| <b>Trouble</b>   | <b>Probable Cause</b>  | <b>Remedy</b>  |
|--|------------------------|--|
| Machine will not start/restart or repeatedly trips circuit breaker or blows fuses. | Miswiring of the unit. | Double check to confirm all electrical connections are correct. Refer to wiring diagram on page 43 to make any needed corrections.   |
|  | On/off switch failure. | If the on/off switch is suspect, you have two options: Have a qualified electrician test the switch for function or purchase a new on/off switch and establish if that was the problem on changeout. |

## Optional Accessories

6296046 .....Knives (set of 3) – for model PJ-882 & PJ882T only

1791212 .....Knife Inserts (set of 10) – for model PJ-882HH & PJ-882HHT only

## Replacement Parts

Replacement parts are listed on the following pages. To order parts or reach our service department, call 1-800-274-6848, Monday through Friday (see our website for business hours, [www.powermatic.com](http://www.powermatic.com)). Having the Model Number and Serial Number of your machine available when you call will allow us to serve you quickly and accurately.

Non-proprietary parts, such as fasteners, can be found at local hardware stores, or may be ordered from Powermatic. Some parts are shown for reference only and may not be available individually.

## Parts List: Stand Assembly

| Index No. | Part No.     | Description                       | Size            | Qty |
|-----------|--------------|-----------------------------------|-----------------|-----|
| 1         | VB-A50       | Belt                              | A-50            | 1   |
| 2         | TS-0267021   | Socket Set Screw                  | 1/4"-20x1/4"    | 2   |
| 3         | PJ882-503    | Motor Pulley                      |                 | 1   |
| 4         | PJ882-205    | Key                               | 5x5x22          | 1   |
| 5         | TS-0561021   | Hex Nut                           | 5/16"-18        | 4   |
| 6         | TS-0680031   | Flat Washer                       | 5/16"           | 8   |
| 7         | 60B-415      | Motor                             | 2HP, 1Ph,230V   | 1   |
|           | 60B-415MF    | Motor Fan (not shown)             |                 | 1   |
|           | 60B-415MFC   | Motor Fan Cover (not shown)       |                 | 1   |
|           | 60B-415CS    | Centrifugal Switch (not shown)    |                 | 1   |
|           | 60B-415MDC   | Motor Dustproof Cover (not shown) |                 | 1   |
|           | 60B-415CC    | Capacitor Cover (not shown)       |                 | 2   |
|           | 60B-415SC    | Starting Capacitor (not shown)    | 400MFD, 125VAC  | 1   |
|           | 60B-415RC    | Running Capacitor (not shown)     | 30uf, 350VAC    | 1   |
| 8         | TS-0267041   | Socket Set Screw                  | 1/4"-20x3/8"    | 2   |
| 9         | PJ882-509    | Shaft                             |                 | 2   |
| 10        | TS-1540071   | Hex Nut                           | M10x1.5P        | 2   |
| 11        | TS-1550071   | Flat Washer                       | M10             | 2   |
| 12        | PJ882-512    | Bolt                              |                 | 1   |
| 13        | PJ882-513    | Motor Base Plate                  |                 | 1   |
| 14        | TS-0720081   | Lock Washer                       | 5/16"           | 6   |
| 15        | TS-0051071   | Hex Cap Screw                     | 5/16"-18x1-1/2" | 4   |
| 16        | TS-081F032   | Pan Head Screw                    | 1/4"-20x1/2"    | 4   |
| 17        | TS-0680021   | Flat Washer                       | 1/4"            | 4   |
| 18        | 60B-425      | Dust Chute                        |                 | 1   |
| 19        | 3520B-140    | Powermatic Nameplate              |                 | 1   |
| 20        | 6296150      | Warning Label                     |                 | 1   |
| 21        | PJ882-521    | Stand                             | 1PH             | 1   |
| 22        | PJ882-522    | Bushing                           |                 | 2   |
| 23        | TS-2276081   | Socket Set Screw                  | M6x1.0Px8       | 2   |
| 24        | PJ882-524    | Motor Cord                        | 1Ph             | 1   |
| 25        | PJ882-525A   | Switch Cord                       |                 | 1   |
| 26        | PJ882-526A   | Magnetic Switch                   | 1Ph 230V        | 1   |
|           | PJ882-526ACS | Contactors Switch (not shown)     | 1Ph 230V        | 1   |
|           | PJ882-526AOR | Overload Relay (not shown)        | for 1Ph         | 1   |
| 27        | 60B-448      | Switch Plate                      |                 | 1   |
| 28        | TS-1533032   | Pan Head Screw                    | M5x0.8Px10      | 4   |
| 29        | 60B-440      | Strain Relief                     | 1Ph             | 1   |
| 30        | PJ882HH-530  | Power Cord                        | 1Ph             | 1   |
| 31        | TS-081F051   | Flat Head Screw                   | 1/4"-20x3/4"    | 4   |
| 32        | PJ882-532    | Door                              |                 | 1   |
| 33        | PJ882-533    | Cord Protector                    | NB-1722         | 2   |
| 34        | PJ882-534A   | Switch Arm                        |                 | 1   |
| 35        | TS-0680021   | Flat Washer                       | 1/4"            | 4   |
| 36        | TS-0207011   | Socket Head Cap Screw             | 1/4"-20x3/8"    | 4   |
| 43        | PJ882-543    | Electric Label                    | 1Ph             | 1   |
| 45        | 60B-447      | Strain Relief                     | 1Ph             | 1   |
| 46        | PJ882-546    | Control Switch                    |                 | 1   |
| 47        | PJ882-547    | Switch Bracket                    |                 | 1   |
| 48        | PJ882-548    | Switch Plate                      |                 | 1   |
| 49        | TS-1550031   | Flat Washer                       | M5              | 6   |
| 50        | JWBS18-447   | Screw                             | M5x8            | 10  |
| 51        | PJ882-551    | Machine Screw                     | M5x50           | 2   |
| 52        | PM2000-298   | Safety Key for Switch             |                 | 1   |
| 53        | TS-0208041   | Socket Head Cap Screw             | 5/16-18x3/4     | 2   |
| 54        | TS-0732041   | Star Washer                       | M5              | 3   |



| <b>Index No.</b> | <b>Part No.</b> | <b>Description</b>               | <b>Size</b> | <b>Qty</b>   |
|------------------|-----------------|----------------------------------|-------------|--------------|
| 55               | 60B-447         | Strain Relief                    |             | 1            |
| 61               | 60C-452         | Cord Plate                       |             | 1            |
| 62               | F000059         | Slotted Round Head Machine Screw | #10-24x1/4  | 2            |
|                  | PM2700-440      | Wide Stripe (not shown)          |             | sold per ft. |
|                  | PM2700-441      | Narrow Stripe (not shown)        |             | sold per ft. |

# Stand Assembly

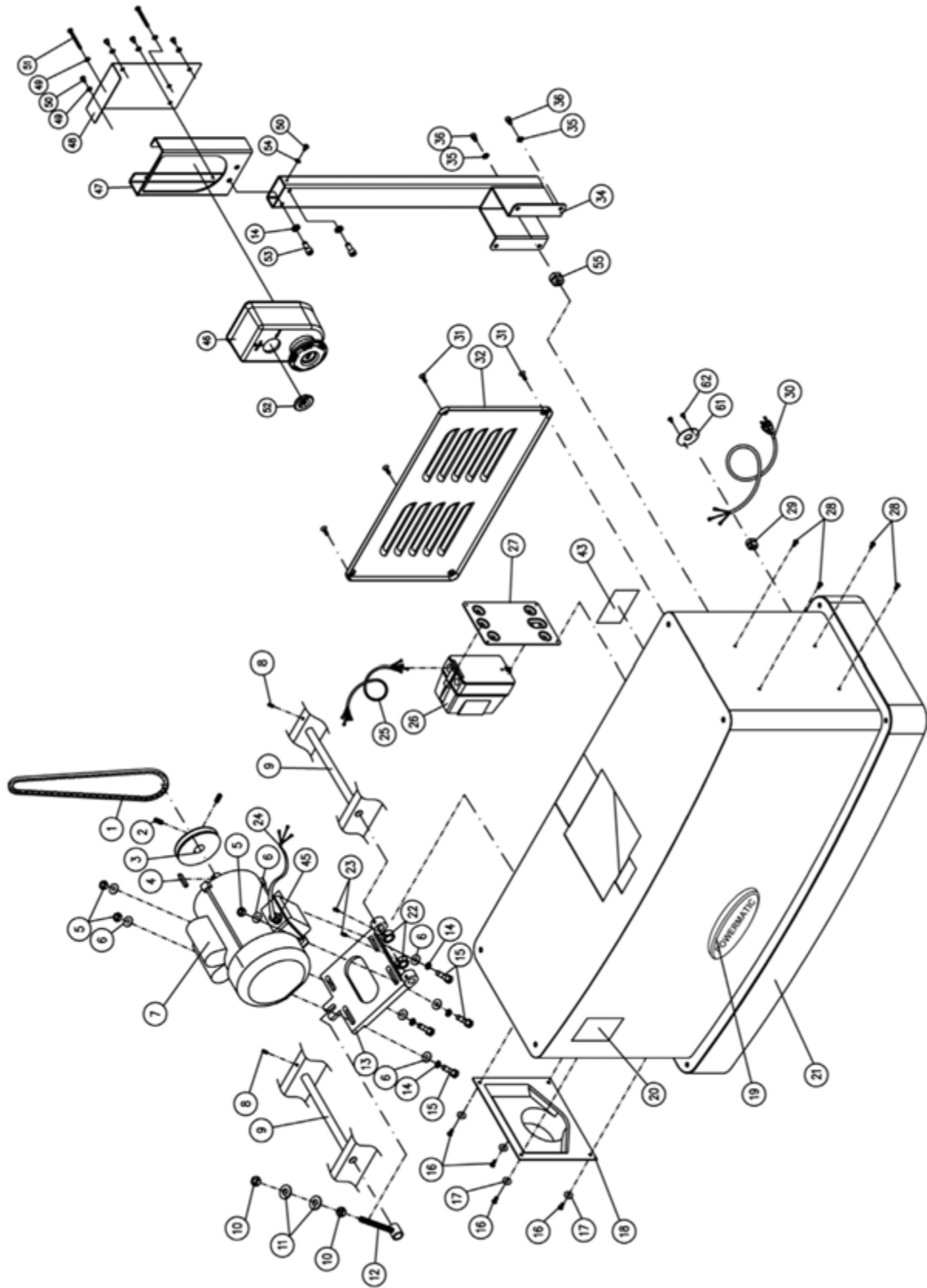

## Parts List: Cutterhead Assembly (Model PJ-882 & PJ882T only)

| Index No. | Part No.   | Description  | Size         | Qty |
|-----------|------------|--|--------------|-----|
| .....     | PJ882-CHA  | Cutterhead Assembly (Items 1 thru 5, and 10 thru 13) |              |     |
| 1         | 6296046    | Knife  |              | 3   |
| 2         | 6296153    | Knife Gib  |              | 3   |
| 3         | 6296048    | Key  | 5x5x25 mm    | 1   |
| 4         | BB-6204VV  | Ball Bearing   | 6204-2NSE    | 2   |
| 5         | PJ882-405  | Bearing Housing                                      |              | 2   |
| 6         | TS-0267021 | Socket Set Screw                                     | 1/4"-20x1/4" | 2   |
| 7         | PJ882-407  | Pulley   |              | 1   |
| 8         | PJ882-408  | Bolt   |              | 2   |
| 9         | TS-0720091 | Lock Washer  | 3/8"         | 2   |
| 10        | 6296154    | Square Head Screw                                    |              | 15  |
| 11        | PJ882-411  | Cutterhead   |              | 1   |
| 12        | 6296054    | Spring   |              | 6   |
| 13        | TS-1513021 | Socket Flat Head Screw                               | M5x0.8Px12   | 6   |
| 14        | PJ882-414  | Direction Label                                      |              | 1   |
| 15        | PJ882-415  | Knife Gauge  |              | 1   |

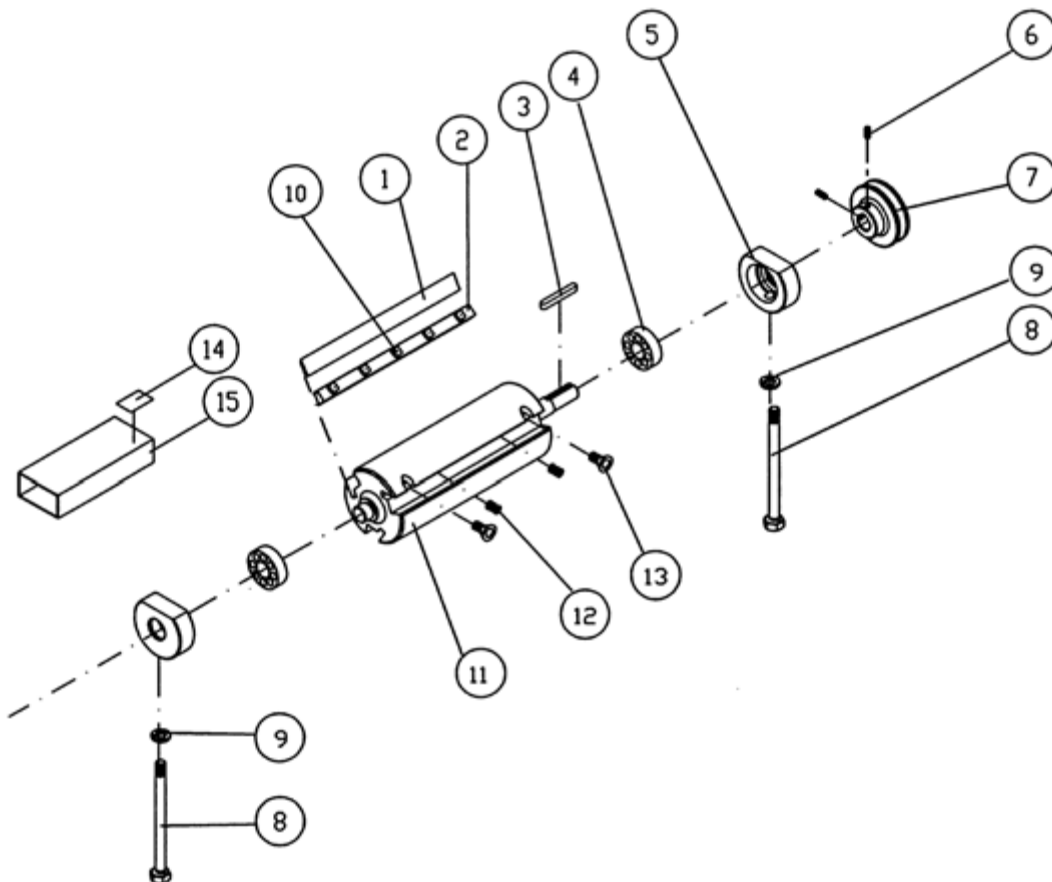

**Parts List: Cutterhead Assembly (Model PJ-882HH & PJ-882HHT only)**

| Index No. | Part No.         | Description                                      | Size              | Qty      |
|-----------|------------------|--|-------------------|----------|
| .....     | PJ882HH-CA.....  | Cutterhead Assembly (Index # 1-10).....          |                   | 1        |
| 1.....    | TS-0267021.....  | Socket Set Screw .....                           | 1/4"-20x1/4"..... | 2        |
| 2.....    | PJ882-407.....   | Cutterhead Pulley .....                          |                   | 1        |
| 3.....    | PJ882-405.....   | Bearing Housing .....                            |                   | 2        |
| 4.....    | BB-6204VV.....   | Ball Bearing .....                               | 6204-2NSE .....   | 2        |
| 5.....    | 5F-G107 .....    | Key.....   | 5x5x22 mm .....   | 1        |
| .....     | 1791222-6 .....  | Helical Cutterhead Unit (Index # 6 thru 8) ..... |                   | 1        |
| 6.....    | 1791212 .....    | Knife Insert (set of 10) .....                   |                   | total 54 |
| 7.....    | JWP208HH-111 ... | Knife Insert Screw.....                          | #10-32x1/2".....  | 54       |
| 8.....    | PJ882HH-408..... | Helical Cutterhead .....                         |                   | 1        |
| 9.....    | TS-0720091.....  | Lock Washer.....                                 | 3/8".....         | 2        |
| 10.....   | PJ882-408.....   | Bolt.....  |                   | 2        |
| 11.....   | JJ6HH-113 .....  | Star Point Screwdriver (not shown).....          |                   | 2        |

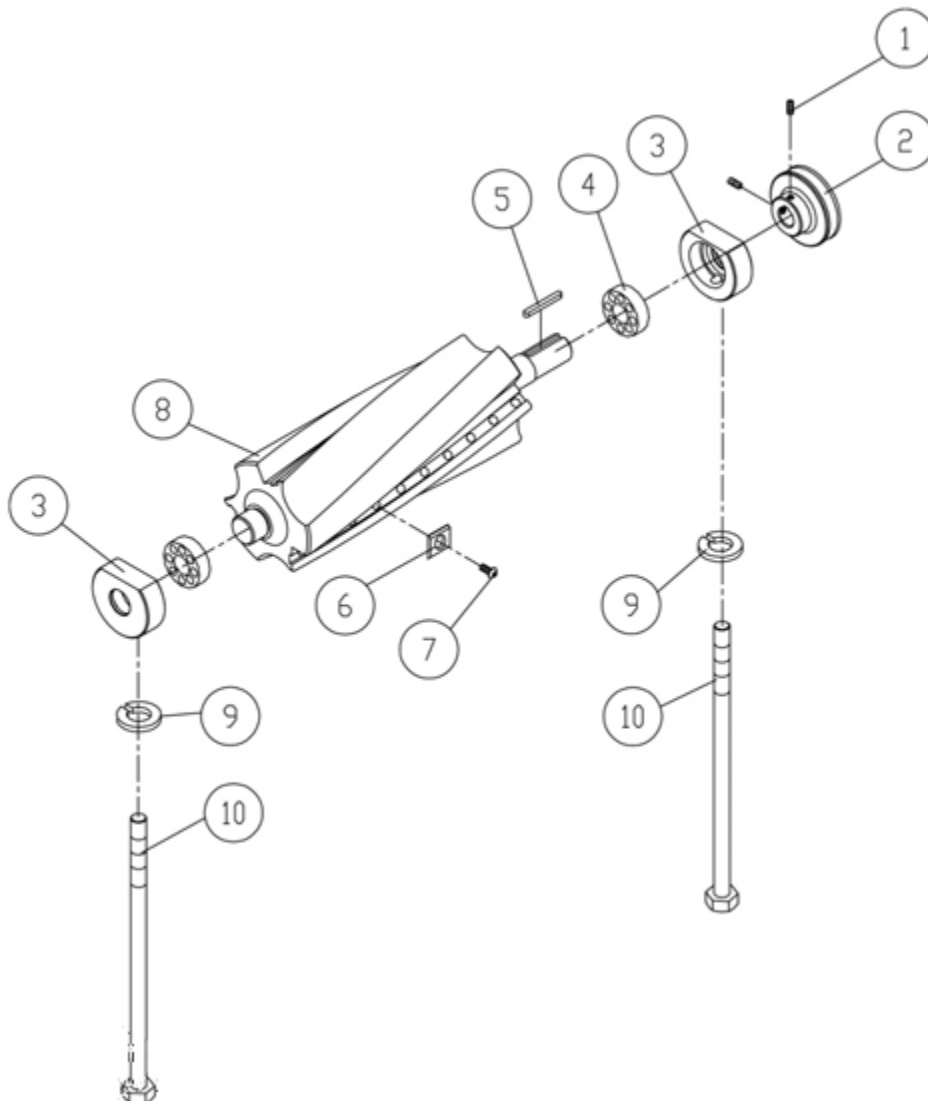

## Parts List: Fence Assembly

| Index No. | Part No.   | Description   | Size           | Qty |
|-----------|------------|---|----------------|-----|
|           | PJ882-FA   | Fence Assembly (Index #1 thru #49).( models PJ-882 & PJ-882HH)  |                |     |
|           | PJ882-FAT  | Fence Assembly (Index #1 thru #49). (models PJ882T & PJ-882HHT) |                |     |
| 1         | PJ882-101  | Hand Wheel  |                | 1   |
| 2         | TS-0267021 | Socket Set Screw  | 1/4"-20x1/4"   | 3   |
| 3         | TS-0207031 | Socket Head Cap Screw   | 1/4"-20x5/8"   | 4   |
| 4         | PJ882-104  | Bearing Cover   |                | 1   |
| 5         | PJ882-105  | C-Ring  | STW-12         | 2   |
| 6         | PJ882-106  | Worm Shaft  |                | 1   |
| 7         | BB-6001ZZ  | Ball Bearing  | 6001ZZ         | 2   |
| 8         | PJ882-108  | Pin   | Ø3x20 mm       | 1   |
| 9         | TS-0810012 | Screw   | #10-24x1/4"    | 2   |
| 10        | TS-0680011 | Flat Washer   | 3/16"          | 2   |
| 11        | PJ882-111  | Pointer   |                | 1   |
| 12        | 6285945    | Knob  |                | 1   |
| 13        | 6296069    | Locking Shaft   |                | 1   |
| 14        | 6285944    | Handle Stud   |                | 1   |
| 15        | TS-0207021 | Socket Head Cap Screw   | 1/4"-20x1/2"   | 1   |
| 16        | 6296084    | Bolt  |                | 1   |
| 17        | TS-0680061 | Flat Washer   | 1/2"           | 1   |
| 18        | PJ882-118  | Hex Nut   | 1/2"-12        | 2   |
| 19        | PJ882-119  | Locking Handle  |                | 1   |
| 20        | PJ882-120  | Bushing   |                | 1   |
| 21        | PJ882-121  | Stop Block  |                | 1   |
| 22        | PJ882-122  | Fence Bracket   |                | 1   |
| 23        | PJ882-123  | Worm  |                | 1   |
| 24        | PJ882-124  | Retaining Ring  | RTW-28         | 1   |
| 25        | TS-0050031 | Hex Cap Screw   | 1/4"-20x3/4"   | 1   |
| 26        | PJ882-126  | Rack  |                | 1   |
| 27        | PJ882-127  | Locking Handle Nut  |                | 1   |
| 28        | PJ882-128  | Locking Link  |                | 1   |
| 29        | TS-0561011 | Hex Nut   | 1/4"-20        | 3   |
| 30        | F007239    | Hex Cap Screw   | 1/4"-20x1-1/4" | 2   |
| 31        | PJ882-131  | Safety Plate  |                | 1   |
| 32        | TS-081F031 | Flat Head Screw   | 1/4"-20x1/2"   | 2   |
| 33        | 6296070    | Pin   | 5mmx50mm       | 1   |
| 34        | TS-0206021 | Socket Head Cap Screw   | #10-24x1/2"    | 5   |
| 35        | 6296073    | Screw   |                | 1   |
| 36        | 6296082    | Fence Link  |                | 1   |
| 37        | 6285942    | Cone Point Screw  |                | 4   |
| 38        | TS-0561031 | Hex Nut   | 3/8"-16        | 4   |
| 39        | TS-0720071 | Lock Washer   | 1/4"           | 2   |
| 40        | 6285940    | Pivot Stud  |                | 2   |
| 41        | TS-0561052 | Hex Nut   | 1/2"-20        | 2   |
| 42        | PJ882-142  | Fixed Block   |                | 1   |
| 43        | PJ882-143  | Fence (models PJ-882 & PJ-882HH)                                |                | 1   |
|           | PJ882-143T | Fence (models PJ882T & PJ-882HHT)                               |                | 1   |
| 44        | PJ882-144  | Insert  |                | 1   |
| 45        | 60B-130    | Caution Label (Setting Knives)                                  |                | 1   |
| 46        | 60B-129    | Caution Label (Hands Clear)                                     |                | 1   |
| 47        | PJ882-147  | Label (Lock/ Unlock)  |                | 1   |
| 48        | PJ882-148  | Scale Label   |                | 1   |
| 49        | PJ882-333  | Spring Pin  | Ø4x25 mm       | 1   |

# Fence Assembly

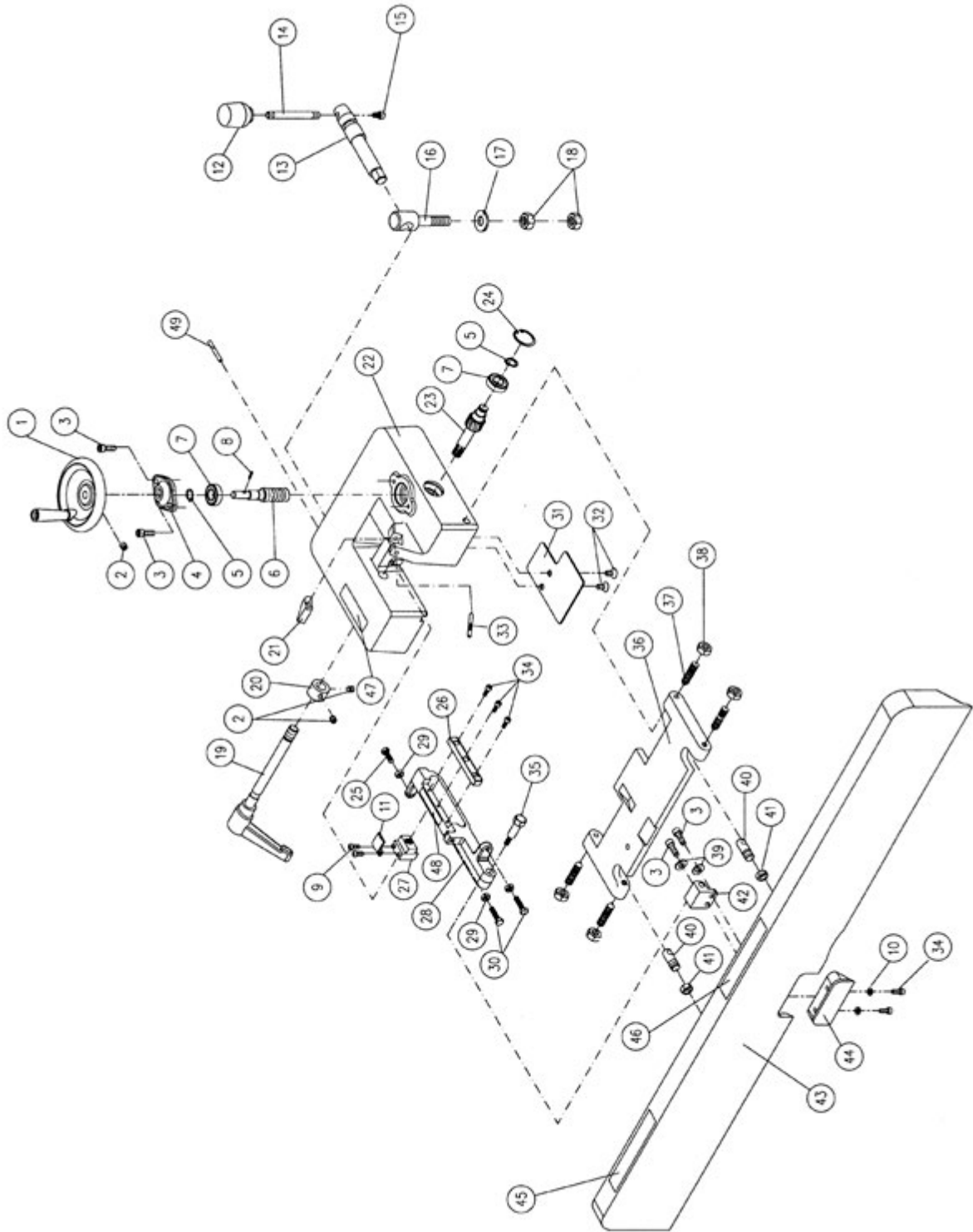

## Parts List: Outfeed Table and Base Assembly

| Index No. | Part No.   | Description                                      | Size           | Qty |
|-----------|------------|--|----------------|-----|
| 1         | PJ882-201  | Rear (Outfeed) Table (models PJ-882 & PJ-882HH)  |                | 1   |
|           | PJ882-201T | Rear (Outfeed) Table (models PJ882T & PJ-882HHT) |                | 1   |
| 2         | 6285917    | Push Block                                       |                | 2   |
| 3         | PJ882-203  | Shaft  |                | 2   |
| 4         | PJ882-204  | Shaft  |                | 1   |
| 5         | PJ882-205  | Key  | 5x5x22 mm      | 1   |
| 6         | PJ882-206  | Knob   |                | 1   |
| 7         | PJ882-207  | Handle   |                | 1   |
| 8         | PJ882-208  | Table Raising Link                               |                | 1   |
| 9         | TS-0270031 | Socket Set Screw                                 | 5/16"-18x3/8"  | 12  |
| 10        | TS-0271031 | Socket Set Screw                                 | 3/8"-16x3/8"   | 2   |
| 11        | PJ882-211  | Shaft  |                | 1   |
| 12        | PJ882-212  | Table Lip  |                | 1   |
| 13        | TS-0680011 | Flat Washer                                      | 3/16"          | 3   |
| 14        | TS-0810012 | Screw  | #10-24x1/4"    | 3   |
| 15        | PJ882-215  | Slide Bracket                                    |                | 1   |
| 16        | 6296058    | Knob   |                | 1   |
| 17        | PJ882-217  | Belt Guard                                       |                | 1   |
| 18        | TS-0060051 | Hex Cap Screw                                    | 3/8"-16x1"     | 1   |
| 19        | TS-0561031 | Hex Nut  | 3/8"-16        | 3   |
| 20        | TS-0060121 | Hex Cap Screw                                    | 3/8"-16x2-3/4" | 4   |
| 21        | TS-0680041 | Flat Washer                                      | 3/8"           | 4   |
| 22        | PJ882-222  | Plastic Washer                                   | 3/8"           | 4   |
| 23        | PJ882-223  | Plug   |                | 4   |
| 24        | PJ882-224  | Socket Head Cap Screw                            | 1/2"-12x3"     | 1   |
| 25        | PJ882-118  | Hex Nut  | 1/2"-12        | 1   |
| 26        | TS-0271101 | Socket Set Screw                                 | 3/8"-16x1-1/4" | 2   |
| 27        | PJ882-227  | Copper Bushing                                   |                | 3   |
| 28        | PJ882-228  | Adjustment Nut                                   |                | 4   |
| 29        | PJ882-229  | Shaft  |                | 2   |
| 30        | PJ882-230  | E-Ring   | ETW-12         | 2   |
| 31        | TS-0208031 | Socket Head Cap Screw                            | 5/16"-18x5/8"  | 1   |
| 32        | TS-0680031 | Flat Washer                                      | 5/16"          | 1   |
| 33        | PJ882-233  | Hub  |                | 1   |
| 34        | PJ882-234  | Locking Handle                                   |                | 1   |
| 35        | TS-0270031 | Socket Set Screw                                 | 5/16"-18x3/8"  | 3   |
| 36        | PJ882-236  | Base   |                | 1   |
| 37        | TS-0207021 | Socket Head Cap Screw                            | 1/4"-20x1/2"   | 1   |
| 38        | 6296088    | Spring Pin                                       | Ø4x14 mm       | 1   |
| 39        | 6296089    | Key  |                | 1   |
| 40        | 6296042    | Washer   |                | 2   |
| 41        | TS-0209061 | Socket Head Cap Screw                            | 3/8"-16x1-1/4" | 2   |
| 42        | PJ882-242  | Stud   |                | 1   |
| 43        | PJ882-243  | ID Label (models PJ-882 & PJ-882HH)              | 1Ph            | 1   |
|           | PJ882-243T | ID Label (models PJ882T & PJ-882HHT)             | 1Ph            | 1   |
| 44        | 6296148    | Rivet  |                | 2   |
| 45        | TS-0209031 | Socket Head Cap Screw                            | 3/8"-16x3/4"   | 2   |
| 46        | PJ882-246  | Key  | 5x5x20 mm      | 2   |
| 47        | TS-0050031 | Hex Cap Screw                                    | 1/4"-20x3/4"   | 2   |
| 48        | PJ882-248  | Table Raising Link                               |                | 1   |

# Outfeed Table and Base Assembly

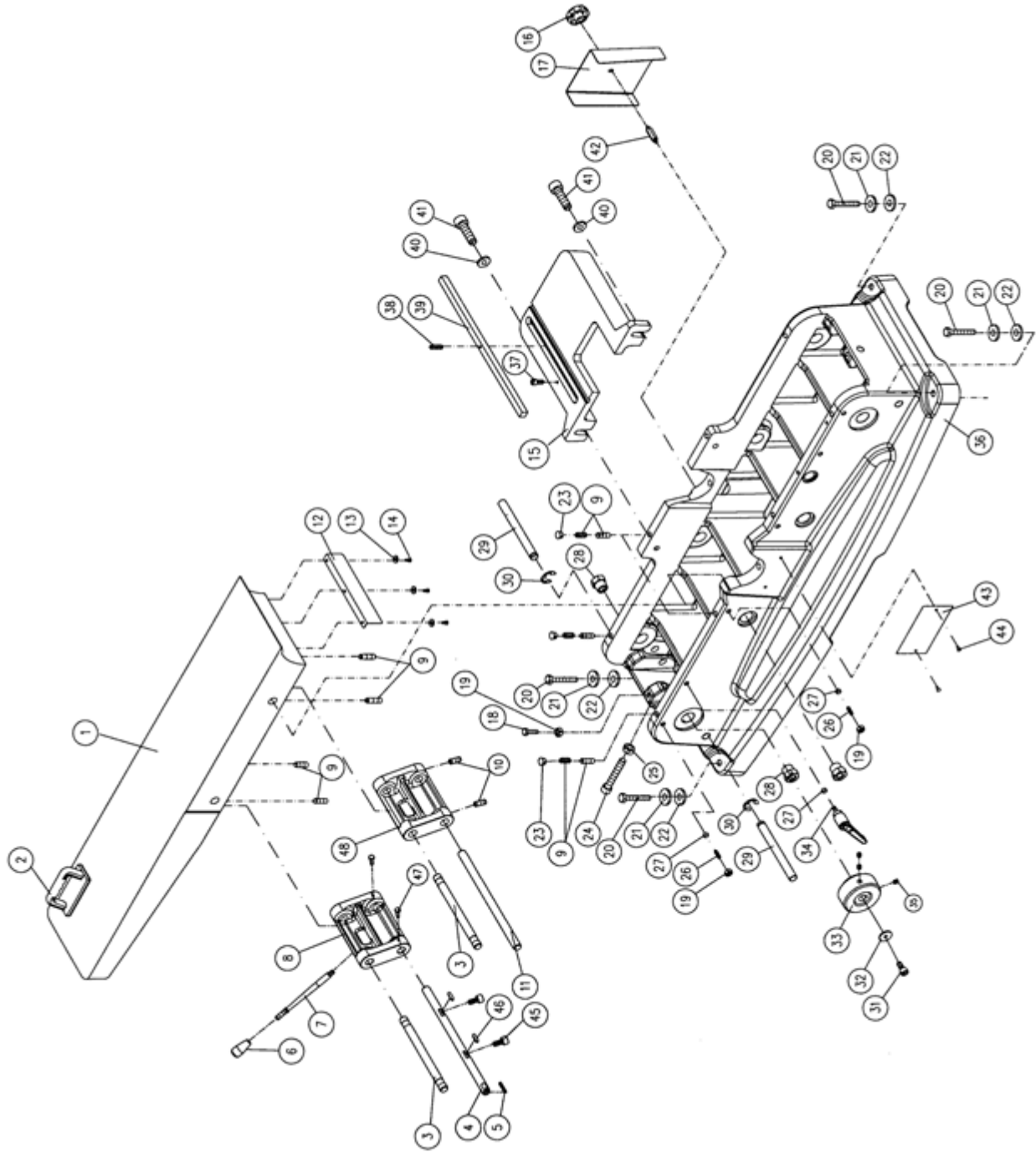



## Parts List: Infeed Table Assembly

| Index No. | Part No.   | Description                                      | Size           | Qty |
|-----------|------------|--|----------------|-----|
| 1         | PJ882-301  | Front (Infeed) Table (models PJ-882 & PJ-882HH)  |                | 1   |
|           | PJ882-301T | Front (Infeed) Table (models PJ882T & PJ-882HHT) |                | 1   |
| 2         | PJ882-302  | Scale Label                                      |                | 1   |
| 3         | PJ882-203  | Shaft  |                | 2   |
| 4         | PJ882-304  | Shaft  |                | 1   |
| 5         | PJ882-205  | Key  | 5x5x22 mm      | 1   |
| 6         | 6296148    | Rivet  |                | 2   |
| 7         | TS-0270051 | Socket Set Screw                                 | 5/16"-18x1/2"  | 1   |
| 8         | PJ882-208  | Table Raising Link                               |                | 1   |
| 9         | TS-0270031 | Socket Set Screw                                 | 5/16"-18x3/8"  | 12  |
| 10        | TS-0271031 | Socket Set Screw                                 | 3/8"-16x3/8"   | 2   |
| 11        | PJ882-211  | Shaft  |                | 1   |
| 12        | PJ882-212  | Table Lip  |                | 1   |
| 13        | TS-0680011 | Flat Washer                                      | 3/16"          | 3   |
| 14        | TS-0810012 | Screw  | #10-24x1/4"    | 3   |
| 15        | 60B-273    | Cutterhead Guard (models PJ-882 & PJ-882HH)      |                | 1   |
|           | 60B-273T   | Cutterhead Guard (models PJ882T & PJ-882HHT)     |                | 1   |
| 16        | JSG96-223  | Retaining Ring                                   | STW-11         | 1   |
| 17        | 60B-272    | Warning Label                                    |                | 1   |
| 18        | TS-0060051 | Hex Cap Screw                                    | 3/8"-16x1"     | 3   |
| 19        | TS-0561031 | Hex Nut  | 3/8"-16        | 3   |
| 20        | TS-0813022 | Round Head Screw                                 | 1/4"-20x3/8"   | 1   |
| 21        | PJ882-321  | Pointer  |                | 1   |
| 22        | PJ882-322  | Lift Handle Hub                                  |                | 1   |
| 23        | PJ882-223  | Plug   |                | 4   |
| 24        | PJ882-224  | Socket Head Cap Screw                            | 1/2"-12x3"     | 1   |
| 25        | PJ882-118  | Hex Nut  | 1/2"-12        | 1   |
| 26        | TS-0271101 | Socket Set Screw                                 | 3/8"-16x1-1/4" | 2   |
| 27        | PJ882-227  | Copper Bushing                                   |                | 3   |
| 28        | PJ882-228  | Adjustment Nut                                   |                | 4   |
| 29        | PJ882-229  | Shaft  |                | 2   |
| 30        | PJ882-230  | E-Ring   | ETW-12         | 2   |
| 31        | TS-0208031 | Socket Head Cap Screw                            | 5/16"-18x5/8"  | 1   |
| 32        | TS-0680031 | Flat Washer                                      | 5/16"          | 1   |
| 33        | PJ882-333  | Spring Pin                                       | Ø4x25 mm       | 1   |
| 34        | PJ882-234  | Locking Handle                                   |                | 1   |
| 35        | TS-0270031 | Socket Set Screw                                 | 5/16"-18x3/8"  | 3   |
| 36        | TS-0267021 | Socket Set Screw                                 | 1/4"-20x1/4"   | 1   |
| 37        | PJ882-337  | Block  |                | 1   |
| 38        | PJ882-338  | Stud   |                | 1   |
| 39        | PJ882-339  | Spring   |                | 1   |
| 40        | PJ882-340  | Washer   | 1/4"x1/2"OD    | 1   |
| 41        | PJ882-341  | Knob   |                | 1   |
| 42        | TS-0680021 | Flat Washer                                      | 1/4"           | 1   |
| 43        | TS-0640071 | Nylon Insert Lock Nut                            | 1/4"-20        | 1   |
| 44        | PJ882-344  | Lift Handle                                      |                | 1   |
| 45        | 6296028    | Handle Grip                                      |                | 1   |
| 46        | TS-0680021 | Flat Washer                                      | 1/4"           | 1   |
| 47        | TS-0720071 | Lock Washer                                      | 1/4"           | 1   |
| 48        | TS-0207021 | Socket Head Cap Screw                            | 1/4"-20x1/2"   | 1   |
| 49        | TS-0680041 | Socket Set Screw                                 | 5/16"-18x3/4"  | 1   |
| 50        | TS-0680041 | Flat Washer                                      | 3/8"           | 2   |
| 51        | PJ882-351  | Rabbeting Ledge (models PJ-882 & PJ-882HH)       |                | 1   |
|           | PJ882-351T | Rabbeting Ledge (models PJ882T & PJ-882HHT)      |                | 1   |
| 52        | PJ882-352  | Spring Pin                                       | Ø5x32 mm       | 1   |
| 53        | PJ882-353  | Shaft  |                | 1   |

| Index No. | Part No.   | Description                                   | Size            | Qty |
|-----------|------------|---|-----------------|-----|
| 54        | PJ882-354  | Spring  |                 | 1   |
| 55        | PJ882-355  | Spring Pin                                    | Ø6x25 mm        | 1   |
| 56        | PJ882-246  | Key   | 5x5x20 mm       | 2   |
| 57        | TS-0209031 | Socket Head Cap Screw                         | 3/8"-16x3/4"    | 2   |
| 58        | TS-0050031 | Hex Cap Screw                                 | 1/4"-20x3/4"    | 2   |
| 59        | PJ882-248  | Table Raising Link                            |                 | 1   |
| 60        | PJ882-360T | Non-Marring Strip (models PJ882T & PJ-882HHT) |                 | 1   |
| 61        | TS-1532032 | Phillips Pan-Head Screw (PJ882T & PJ-882HHT)  | M4 x 0.7P x 10L | 4   |

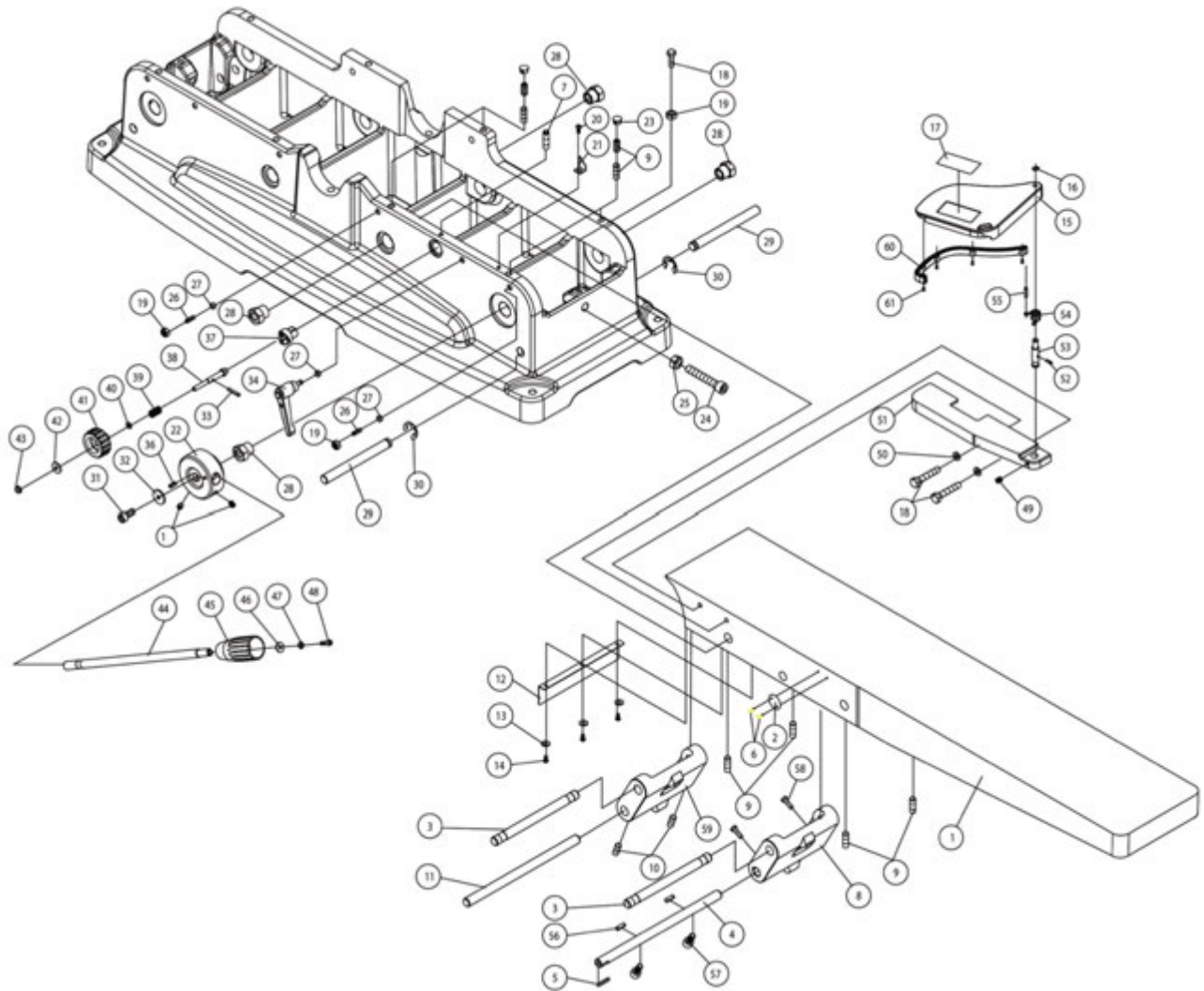

# Electrical Connections – Single-Phase, 230-Volt

230V, 1Ph

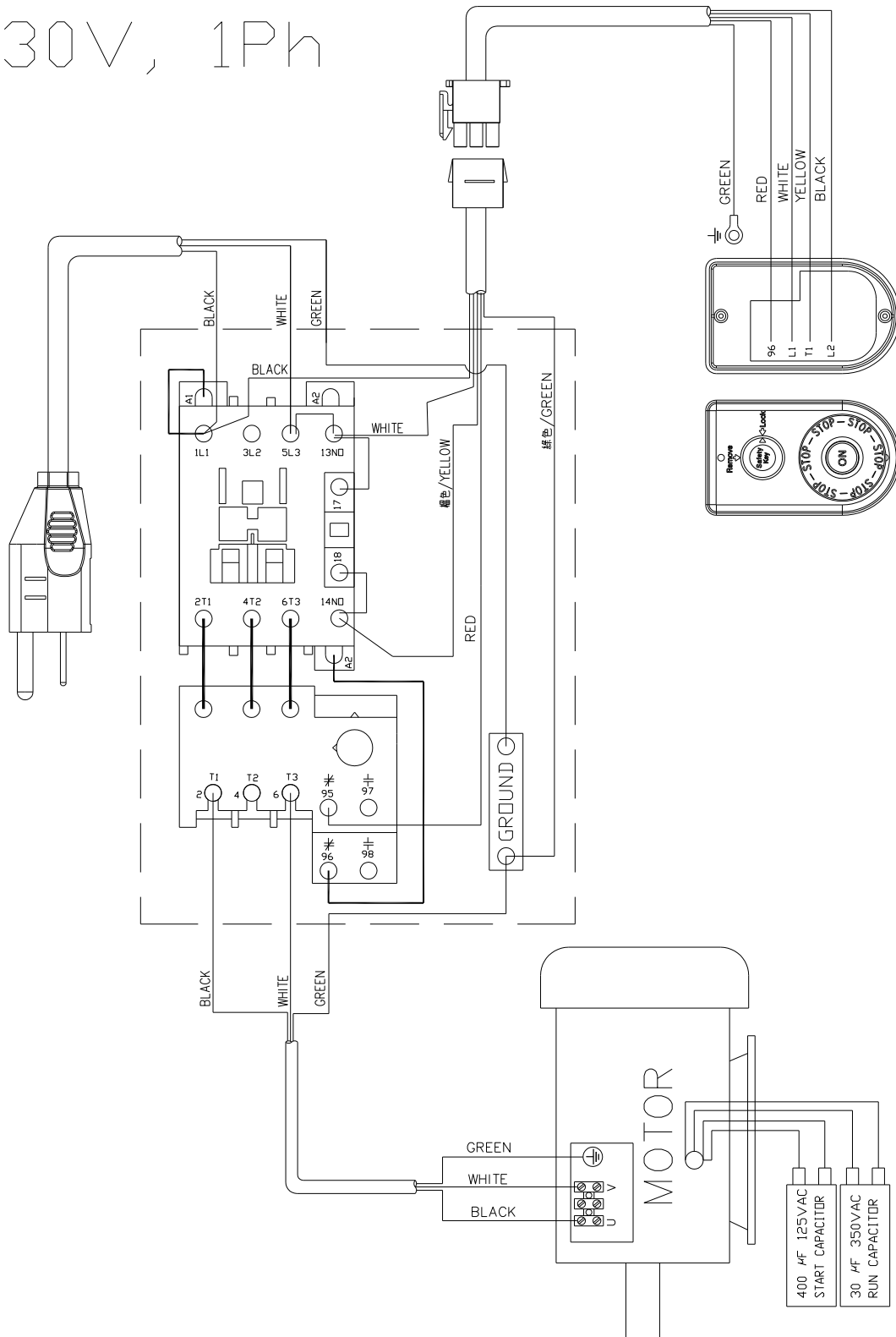



427 New Sanford Road  
LaVergne, Tennessee 37086  
Phone: 800-274-6848  
[www.powermatic.com](http://www.powermatic.com)