

POWERMATIC®

Instructions for 6827045Z Accessory Workbench Table

The Powermatic *Workbench Table* is an optional accessory intended for use with the Powermatic PM2000B Table Saw. It requires minor assembly and will bolt to the rails of the table saw with no drilling needed.

Read carefully the instructions on the following pages for assembly and adjustment procedures.

⚠ WARNING: This product can expose you to chemicals including lead which is known to the State of California to cause cancer and birth defects or other reproductive harm. For more information go to <http://www.p65warnings.ca.gov>.

⚠ WARNING: Drilling, sawing, sanding or machining wood products generates wood dust and other substances known to the State of California to cause cancer. Avoid inhaling dust generated from wood products or use a dust mask or other safeguards for personal protection. Wood products emit chemicals known to the State of California to cause birth defects or other reproductive harm. For more information go to <http://www.p65warnings.ca.gov/wood>.



Powermatic
427 New Sanford Road
LaVergne, Tennessee 37086
Ph.: 800-274-6848
www.powermatic.com

Part No. M-6827045Z
Edition 2 10/2018
Copyright © 2018 Powermatic

Warranty and Service

Powermatic® warrants every product it sells against manufacturers' defects. If one of our tools needs service or repair, please contact Technical Service by calling 1-800-274-6846, 8AM to 5PM CST, Monday through Friday.

Warranty Period

The general warranty lasts for the time period specified in the literature included with your product or on the official Powermatic branded website.

- Powermatic products carry a limited warranty which varies in duration based upon the product. (See chart below)
- Accessories carry a limited warranty of one year from the date of receipt.
- Consumable items are defined as expendable parts or accessories expected to become inoperable within a reasonable amount of use and are covered by a 90 day limited warranty against manufacturer's defects.

Who is Covered

This warranty covers only the initial purchaser of the product from the date of delivery.

What is Covered

This warranty covers any defects in workmanship or materials subject to the limitations stated below. This warranty does not cover failures due directly or indirectly to misuse, abuse, negligence or accidents, normal wear-and-tear, improper repair, alterations or lack of maintenance. Powermatic woodworking machinery is designed to be used with Wood. Use of these machines in the processing of metal, plastics, or other materials outside recommended guidelines may void the warranty. The exceptions are acrylics and other natural items that are made specifically for wood turning.

Warranty Limitations

Woodworking products with a Five Year Warranty that are used for commercial or industrial purposes default to a Two Year Warranty. Please contact Technical Service at 1-800-274-6846 for further clarification.

How to Get Technical Support

Please contact Technical Service by calling 1-800-274-6846. **Please note that you will be asked to provide proof of initial purchase when calling.** If a product requires further inspection, the Technical Service representative will explain and assist with any additional action needed. Powermatic has Authorized Service Centers located throughout the United States. For the name of an Authorized Service Center in your area call 1-800-274-6846 or use the Service Center Locator on the Powermatic website.

More Information

Powermatic is constantly adding new products. For complete, up-to-date product information, check with your local distributor or visit the Powermatic website.

How State Law Applies

This warranty gives you specific legal rights, subject to applicable state law.

Limitations on This Warranty

POWERMATIC LIMITS ALL IMPLIED WARRANTIES TO THE PERIOD OF THE LIMITED WARRANTY FOR EACH PRODUCT. EXCEPT AS STATED HEREIN, ANY IMPLIED WARRANTIES OF MERCHANTABILITY AND FITNESS FOR A PARTICULAR PURPOSE ARE EXCLUDED. SOME STATES DO NOT ALLOW LIMITATIONS ON HOW LONG AN IMPLIED WARRANTY LASTS, SO THE ABOVE LIMITATION MAY NOT APPLY TO YOU. POWERMATIC SHALL IN NO EVENT BE LIABLE FOR DEATH, INJURIES TO PERSONS OR PROPERTY, OR FOR INCIDENTAL, CONTINGENT, SPECIAL, OR CONSEQUENTIAL DAMAGES ARISING FROM THE USE OF OUR PRODUCTS. SOME STATES DO NOT ALLOW THE EXCLUSION OR LIMITATION OF INCIDENTAL OR CONSEQUENTIAL DAMAGES, SO THE ABOVE LIMITATION OR EXCLUSION MAY NOT APPLY TO YOU.

Powermatic sells through distributors only. The specifications listed in Powermatic printed materials and on the official Powermatic website are given as general information and are not binding. Powermatic reserves the right to effect at any time, without prior notice, those alterations to parts, fittings, and accessory equipment which they may deem necessary for any reason whatsoever.

Product Listing with Warranty Period

| |
|---------------------------------------------------------------------------|
| 90 Days – Parts; Consumable items |
| 1 Year – Motors, Machine Accessories |
| 2 Year – Woodworking Machinery used for industrial or commercial purposes |
| 5 Year – Woodworking Machinery |

NOTE: Powermatic is a division of JPW Industries, Inc. References in this document to Powermatic also apply to JPW Industries, Inc., or any of its successors in interest to the Powermatic brand.

Unpacking

Compare contents of shipping carton against the list and illustrations below and on page 4. Report any damage immediately to your distributor. If any parts are missing, contact Powermatic at 800-274-6848.

Remove all loose items from the workbench frame, such as the vise assembly, vise faces, vise handle, legs, cross brace, and hardware package.

Contents of Carton:

Refer to Figures 1 through 5:

| ✓ Part No. | Description | Qty |
|---------------------------------------|--------------------------------------|-----|
| <input type="checkbox"/> 6827045Z-SFA | Steel Frame Assembly | 1 |
| <input type="checkbox"/> 6827045Z-1 | Table Board | 1 |
| <input type="checkbox"/> 6827045Z-16 | Leg | 2 |
| <input type="checkbox"/> 6827045Z-17 | Cross Brace | 1 |
| <input type="checkbox"/> 6827045Z-18 | Omni-Directional Caster | 1 |
| <input type="checkbox"/> 6827045Z-15 | Flanged Hex Nut | 2 |
| <input type="checkbox"/> 6827045Z-14 | Adjustable Foot | 2 |
| <input type="checkbox"/> 6827045Z-28 | Vise Face-1 | 1 |
| <input type="checkbox"/> 6827045Z-29 | Vise Face-2 | 1 |
| <input type="checkbox"/> 6827045Z-VA | Vise Assembly | 1 |
| <input type="checkbox"/> 6827045Z-8 | Wood Screw, M5x30L | 2 |
| <input type="checkbox"/> 6827045Z-31 | Vise Handle Shaft | 1 |
| <input type="checkbox"/> 6827045Z-30 | Vise Handle Cap | 2 |
| <input type="checkbox"/> 6827045Z-9 | Wood Screw, M3x16L | 2 |
| <input type="checkbox"/> TS-1550061 | Flat Washer, M8 | 4 |
| <input type="checkbox"/> TS-2311081 | Hex Nut, M8 | 4 |
| <input type="checkbox"/> TS-1504101 | Socket Head Cap Screw, M8-1.25 x 50 | 2 |
| <input type="checkbox"/> TS-1541031 | Nylon Lock Hex Nut, M8-1.25 | 4 |
| <input type="checkbox"/> F010989 | Socket Head Flat Screw, M8-1.25 x 65 | 4 |
| <input type="checkbox"/> TS-1504131 | Socket Head Cap Screw, M8-1.25 x 70 | 2 |
| <input type="checkbox"/> 6827045Z-4 | Wood Screw, M5x16L | 9 |
| <input type="checkbox"/> 6827045Z-3 | Shim | 8 |

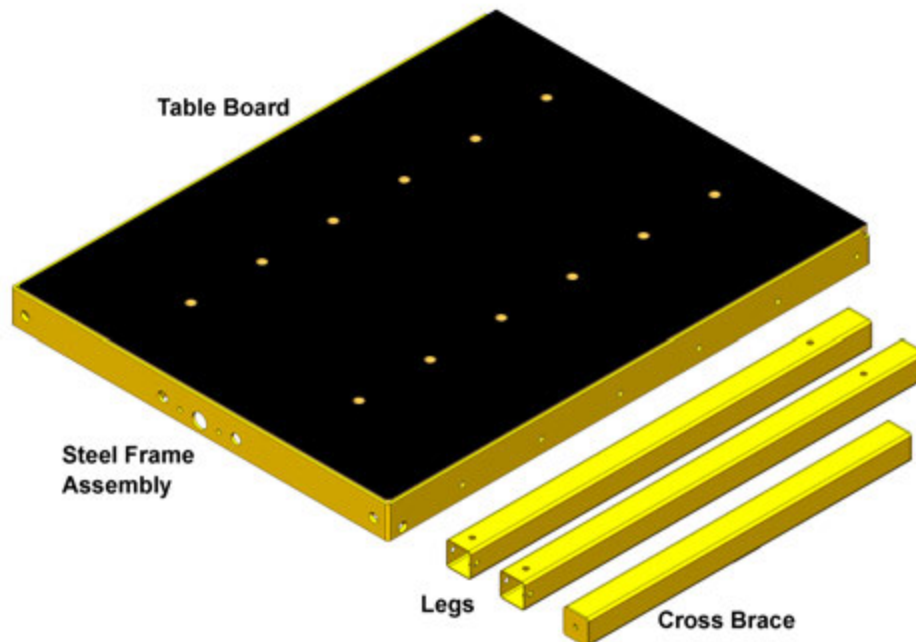
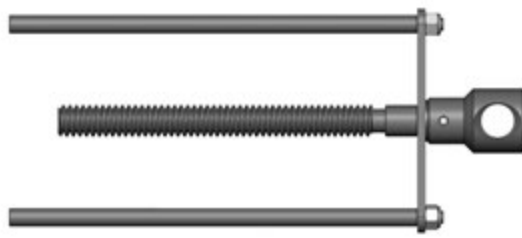

Figure 1



Vise Assembly

Figure 2



Shims

Figure 3



Vise Face-1



Vise Face-2

Figure 4

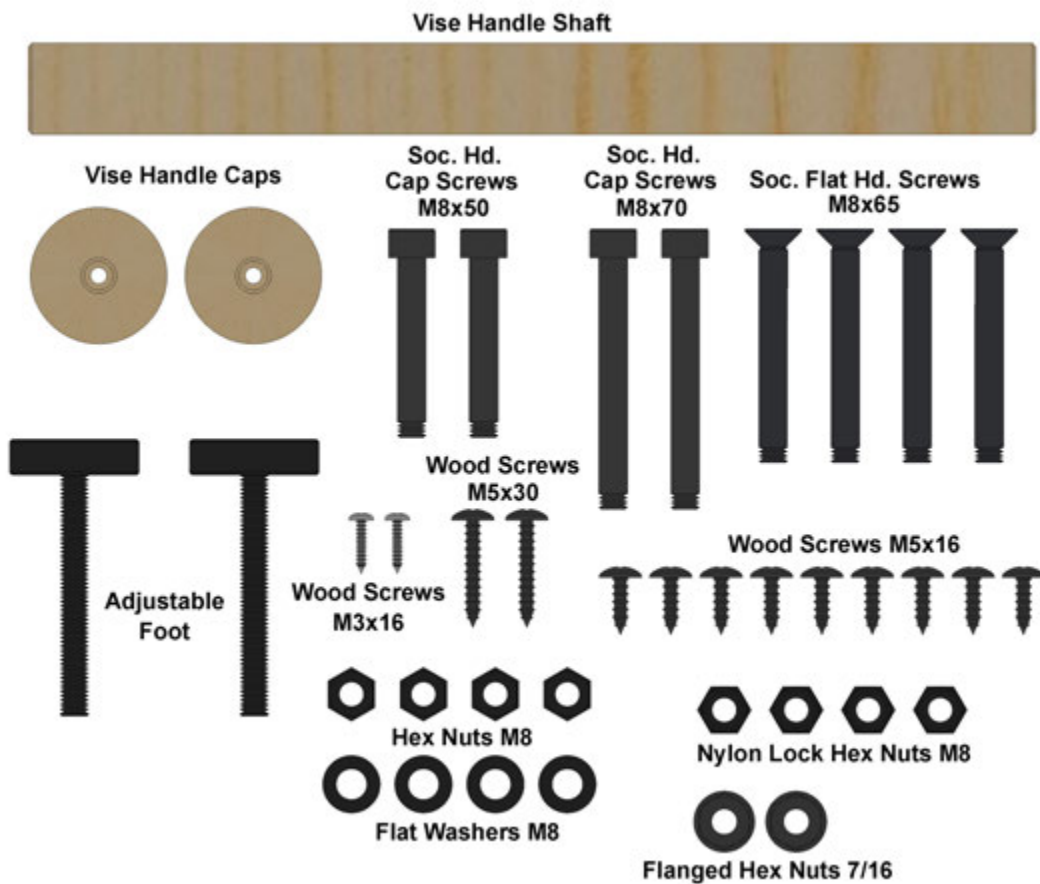

Figure 5

Assembly of Accessory Workbench

If further clarification is needed for any assembly procedure, consult the breakdown on page 7.

Tools Required for Assembly

(not included)

6mm hex (Allen) wrench
Cross point (Phillips) screwdriver
13mm open-end wrench

If desired, apply stain or finish over the natural wood parts before assembly.

TIP: Steps 1 through 4 below are easier if done with table assembly upside down and flat on the floor.

1. Position the *table board* upside down. (Put a mat or cloth under it to prevent scratching the surface.) Place the *steel frame* on top of the table board. Square the steel frame with the table board, and secure using nine *M5x16 wood screws* through the holes in the frame (see Figure 6).
2. With table still lying flat, mount the *vise face-1* to the steel frame. The top surface of *vise face-1* should be flush with the top surface of the workbench. Secure *vise face-1* with two *M8x50 socket head cap screws*, four *M8 flat washers*, and two *M8 hex nuts*, as shown in Figure 7.
3. Insert the *vise assembly* through the holes in *vise face-2*, and through *vise face-1*. Rotate the handle hub to thread it through the bracket on the steel frame.
4. Make sure *vise face-1* and *vise face-2* are flush at the top surfaces, then insert two *M5x30 wood screws*. See Figures 7 and 8. Continue holding the vise faces flush while tightening the wood screws.
5. Slide the *vise handle shaft* into the hub, and secure the two *caps* with the provided *M3x16 wood screws*, as shown in Figure 9.
6. The two provided *legs* are identical. With the workbench upside down, position one leg at a corner (at the vise end of the workbench). See Figure 10. Rotate the leg until the two holes in the leg align with the holes in the steel frame, as shown in Figure 10.
7. Insert two *socket flat head screws* into the holes of the steel frame and through the holes in the leg. Install a *nylon lock hex nut* on each screw and finger tighten only.
8. Install the other leg in the adjacent corner of the table in the same manner. Finger tighten only.

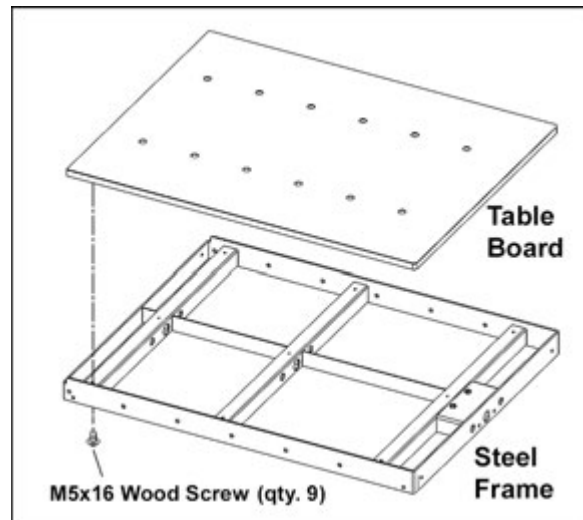

Figure 6

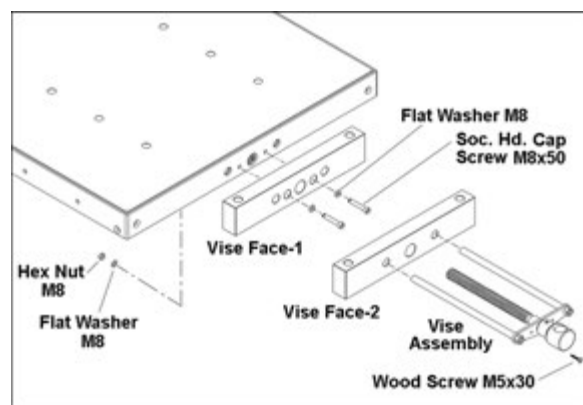

Figure 7

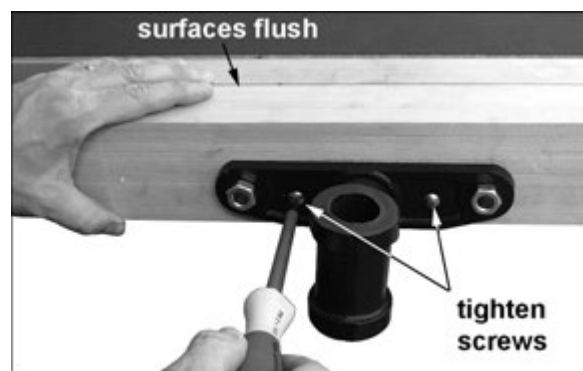

Figure 8

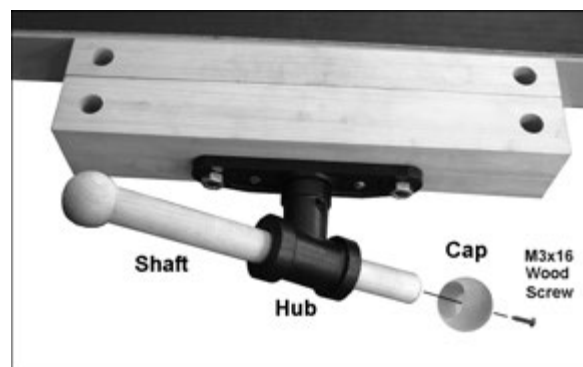

Figure 9

9. Position the *cross brace* between the legs, aligning the holes at the ends of the cross brace with the holes in the legs. NOTE: The flange on cross brace should be oriented as shown in Figure 10.
10. Insert a *socket head cap screw* M8x70 through each leg and into the threaded holes at the ends of the cross brace. Tighten the screws.
11. Fully tighten the four nylon lock hex nuts already installed on the legs.
12. Install an adjustable foot into the threaded hole at the end of each leg (Figure 10).

NOTE: The adjustable foot will be used to level the workbench after it has been installed on the saw. The adjustable foot is rotated in or out to the correct height, and the accompanying hex nut is then tightened against the end of the leg to secure the setting.

13. Install the caster on the cross brace flange with two flanged hex nuts. See Figure 11.
14. Turn the workbench right side up, and position it between the rails of the tablesaw. The workbench should be flush to, and level with, the cast iron table of the saw. (Raise or lower the adjustable feet as needed to assist in this.)
15. Using the fasteners that came with the rails, secure the workbench to the rails. (Refer to the *Accu-Fence* Manual M-2195079B for more detailed information on this.)

16. After the workbench table has been positioned against the table saw, the workbench surface can be raised at certain points using the provided shims. This may help “fine-tune” any leveling or flatness adjustments. Use a straight edge (Figure 12) to check for flatness. (More information on these procedures is available in your *Accu-Fence* manual.) Place a shim as needed between the table underside and the metal braces (see Figure 13).

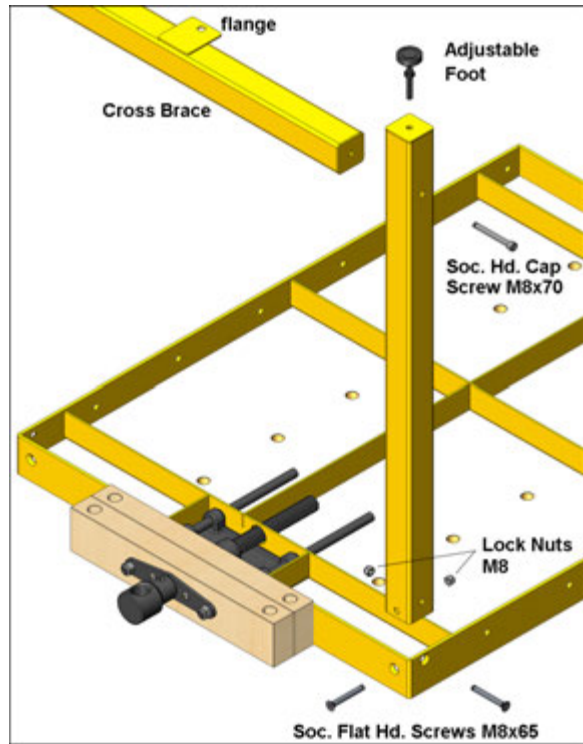

Figure 10



Figure 11



Figure 12



Figure 13

6827045Z PM2000B Accessory Workbench Table – Exploded View

(Refer to parts list on page 8)

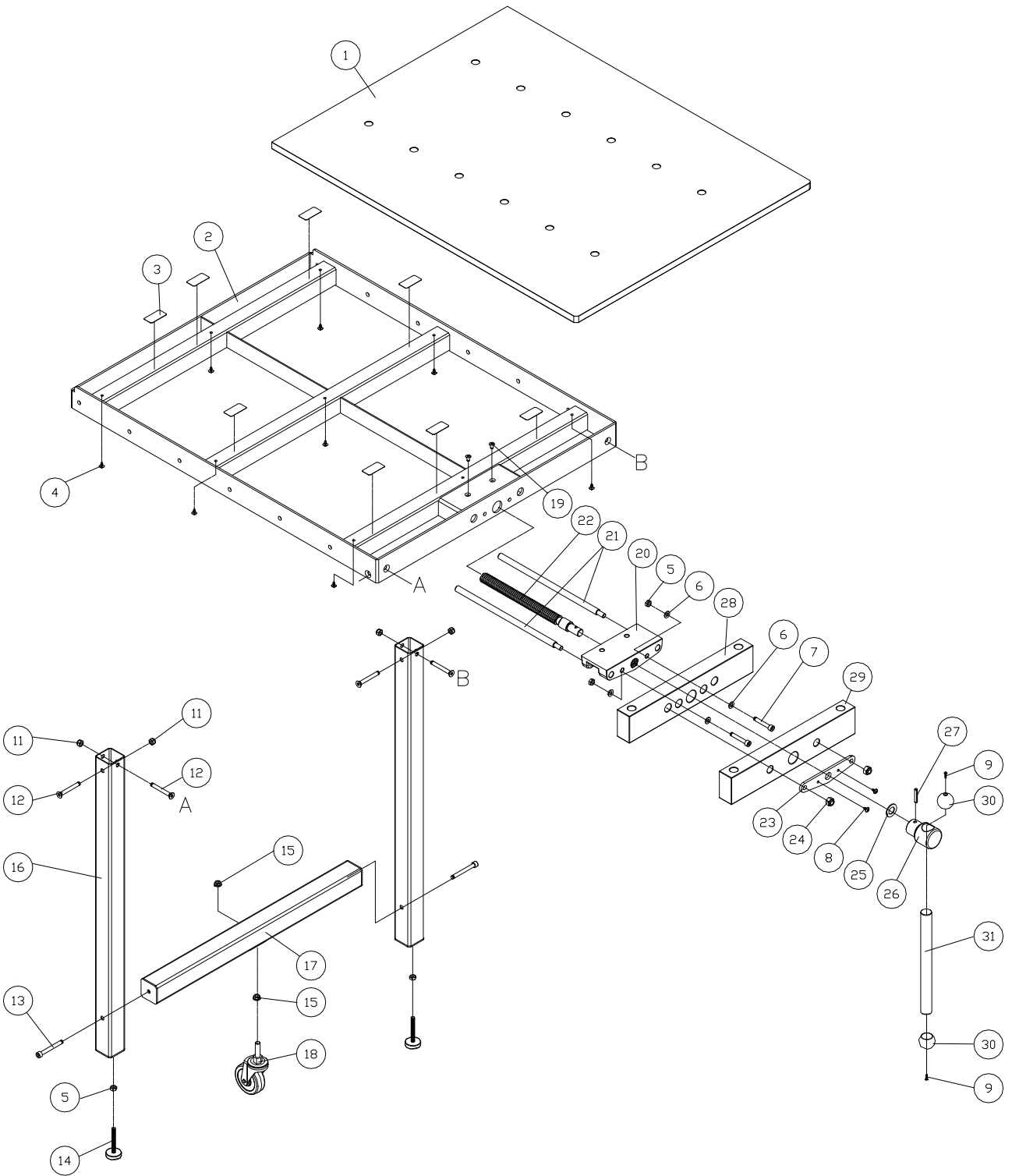

6827045Z PM2000B Accessory Workbench Table – Parts List

| Index No. | Part No. | Description | Size | Qty |
|-----------|--------------|---------------------------------------|-------------------|-----|
| | 6827045Z | Workbench Table (complete assembly) | | |
| 1 | 6827045Z-1 | Table Board | | 1 |
| | 6827045Z-SFA | Steel Frame Assembly (index #2,19,20) | | 1 |
| 2 | 6827045Z-2 | Steel Frame | | 1 |
| 3 | 6827045Z-3 | Shim | | 8 |
| 4 | 6827045Z-4 | Wood Screw | M5 x 16L | 9 |
| 5 | TS-2311081 | Hex Nut | M8-1.25 | 4 |
| 6 | TS-1550061 | Flat Washer | M8 | 4 |
| 7 | TS-1504101 | Socket Head Cap Screw | M8-1.25 x 50 | 2 |
| 8 | 6827045Z-8 | Wood Screw | M5 x 30L | 2 |
| 9 | 6827045Z-9 | Wood Screw | M3 x 16L | 2 |
| 11 | TS-1541031 | Nylon Lock Hex Nut | M8-1.25 | 4 |
| 12 | F010989 | Socket Head Flat Screw | M8-1.25 x 65 | 4 |
| 13 | TS-1504131 | Socket Head Cap Screw | M8-1.25 x 70 | 2 |
| 14 | 6827045Z-14 | Adjustable Foot | | 2 |
| 15 | F003129 | Flanged Hex Nut | 7/16"-14UNC | 2 |
| 16 | 6827045Z-16 | Leg | | 2 |
| 17 | 6827045Z-17 | Cross Brace | | 1 |
| 18 | 6827045Z-18 | Omni-Directional Caster | | 1 |
| 19 | TS-1514011 | Socket Head Flat Screw | M6-1.0 x 12 | 2 |
| 20 | 6827045Z-20 | Mounting Bracket | | 1 |
| | 6827045Z-VA | Vise Assembly (index #8, 21 thru 27) | | 1 |
| 21 | 6827045Z-21 | Spindle | | 1 |
| 22 | 6827045Z-22 | Lead Screw | | 2 |
| 23 | 6827045Z-23 | Face Bracket | | 1 |
| 24 | TS-2342101 | Nylon Lock Hex Nut | M10-1.5 | 2 |
| 25 | TS-2360181 | Flat Washer | 18 x 32 x 2.0T mm | 1 |
| 26 | 6827045Z-26 | Handle Hub | | 1 |
| 27 | F012090 | Roll Pin | 6 x 36 mm | 1 |
| 28 | 6827045Z-28 | Vise Face-1 | | 1 |
| 29 | 6827045Z-29 | Vise Face-2 | | 1 |
| 30 | 6827045Z-30 | Vise Handle Cap | | 2 |
| 31 | 6827045Z-31 | Vise Handle Shaft | | 1 |

Ordering Replacement Parts

Replacement parts are listed on the following pages. To order parts or reach our service department, call 1-800-274-6848 Monday through Friday, 8:00 a.m. to 5:00 p.m. CST. Having the Model Number and Serial Number of your machine available when you call will allow us to serve you quickly and accurately.

Non-proprietary parts, such as fasteners, can be found at local hardware stores, or may be ordered from Powermatic. Some parts are shown for reference only, and may not be available individually.