

POWERMATIC®

Operating Instructions and Parts Manual 10-inch Cabinet Saw Model PM2000B & PM2000BT



For models with serial no. 22022000B2883 and higher

Powermatic
427 New Sanford Road
LaVergne, Tennessee 37086
Ph.: 800-274-6848
www.powermatic.com

Part No. M-PM231B
Edition 6 04/2023
Copyright © 2017 Powermatic



1.0 Safety Warnings

1. Read and understand the entire owner's manual before attempting assembly or operation.
2. Read and understand the warnings posted on the machine and in this manual. Failure to comply with all of these warnings may cause serious injury.
3. Replace the warning labels if they become obscured or removed.
4. This table saw is designed and intended for use by properly trained and experienced personnel only. If you are not familiar with the proper and safe operation of a table saw, do not use until proper training and knowledge have been obtained.
5. Do not use this table saw for other than its intended use. If used for other purposes, Powermatic disclaims any real or implied warranty and holds itself harmless from any injury that may result from that use.
6. Model PM2000BT has an industrial-grade low-friction corrosion-resistant coating on the table and table extensions. While this coating is durable, it can be damaged if metal or other hard and/or sharp objects strike, gouge, or scratch the surface. Significant damage to the coating may affect its performance.
7. Always wear approved safety glasses or face shield while using this table saw. Everyday eyeglasses only have impact resistant lenses; they are not safety glasses.
8. Before operating this table saw, remove tie, rings, watches, and other jewelry, and roll sleeves up past the elbows. Do not wear loose clothing. Confine long hair. Non-slip footwear or anti-skid floor strips are recommended. Do **not** wear gloves.
9. Wear ear protectors (plugs or muffs) during extended periods of operation.
10. Do not operate this machine while tired or under the influence of drugs, alcohol, or any medication.
11. Make certain the machine is properly grounded.
12. Make all machine adjustments or maintenance with the machine unplugged from the power source. A machine under repair should be RED TAGGED to show it must not be used until maintenance is complete.
13. Remove adjusting keys and wrenches. Form a habit of checking to see that keys and adjusting wrenches are removed from the machine before turning it on.
14. Keep safety guards in place at all times when the machine is in use. If removed for maintenance purposes, use extreme caution and replace the guards immediately.
15. Check the alignment of the riving knife, fence, and miter slot to the blade. A caution decal is installed on each guard to remind the operator of the dangers of improper machine operation.
16. Check damaged parts. Before further use of the machine, a guard or other part that is damaged should be carefully checked to determine that it will operate properly and perform its intended function. Check for alignment of moving parts, binding of moving parts, breakage of parts, mounting and any other conditions that may affect its operation. A guard or other part that is damaged should be properly repaired or replaced.
17. Provide for adequate space surrounding work area and non-glare, overhead lighting.
18. Keep the floor around the machine clean and free of scrap material, oil and grease.
19. Keep visitors a safe distance from the work area. Keep children away.
20. Make your workshop child proof with padlocks, master switches or by removing safety keys.
21. Give your work undivided attention. Looking around, carrying on a conversation and "horse-play" are careless acts that can result in serious injury.
22. Maintain a balanced stance at all times so that you do not fall or lean against the blade or other moving parts. Do not overreach or use excessive force to perform any machine operation.
23. Use the right tool at the correct speed and feed rate. Do not force a tool or attachment to do a job for which it was not designed. The right tool will do the job better and safer.
24. Use recommended accessories; improper accessories may be hazardous.
25. Maintain tools with care. Keep blade sharp and clean for the best and safest performance. Follow instructions for lubricating and changing accessories.
26. Check the saw blade for cracks or missing teeth. Do not use a cracked or dull blade or one with missing teeth or improper set. Make sure the blade is securely locked on the arbor.
27. Keep hands clear of the blade area. Do not reach past the blade to clear parts or scrap with the saw blade running. Never saw freehand. Avoid awkward operations and hand positions

where a sudden slip could cause your hand to contact the blade.

28. Do not attempt to saw boards with loose knots or with nails or other foreign material, on its surface. Do not attempt to saw twisted, warped or bowed stock unless one edge has been jointed for guiding purposes prior to sawing. Excessively warped stock should not be used.
29. Do not attempt to saw long or wide boards unsupported where spring or weight could cause the board to shift position.
30. Always use the riving knife, blade guard, push stick and other safety devices for all operations where they can be used. On operations such as dadoing or molding where the blade guard cannot be used, use feather boards, fixtures and other safety devices, and use extreme caution. Reinstall the riving knife and blade guard immediately after completing the operation that required their removal.
31. Be sure the saw blade rotates clockwise when viewed from the motor side (left side) of the machine.
32. Turn off the machine before cleaning. Use a brush or compressed air to remove chips or debris — do not use bare hands.
33. Do not stand on the machine. Serious injury could occur if the machine tips over.
34. Never leave the machine running unattended. Turn the power off and do not leave the machine until it comes to a complete stop.
35. Remove loose items and unnecessary work pieces from the area before starting the machine.
36. Blade should have minimum exposure during cuts. Adjust blade to approximately 1/8" inch above surface of workpiece.

1.1 Kickback

The most common accidents among table saw users, according to statistics, can be linked to kickback, the high-speed expulsion of material from

the table that can strike the operator. Kickback can also result in the operator's hands being pulled into the blade.

Kickback Prevention

Tips to avoid the most common causes of kickback:

- Make sure the riving knife is always aligned with the blade. A workpiece can bind or stop the flow of the cut if the riving knife is misaligned, and result in kickback.
- Use a riving knife during every cut. The riving knife maintains the kerf in the workpiece, which will reduce the chance of kickback.
- Never attempt freehand cuts. The workpiece must be fed parallel to the blade, otherwise kickback will likely occur. Always use the rip fence or miter gauge to support the workpiece.
- Make sure that rip fence is parallel to blade. If not, the chances of kickback are very high. Take the time to check and adjust the rip fence.
- Feed cuts through to completion. Anytime you stop feeding a workpiece that is in the middle of a cut, the chance of binding, resulting in kickback, is greatly increased.

Tips for Kickback Protection

Kickback can happen even if precautions are taken to prevent it. Listed below are some tips to protect you if kickback *does* occur:

- Stand to the side of the blade when cutting. An ejected workpiece usually travels directly in front of the blade.
- Wear safety glasses or a face shield. Your eyes and face are the most vulnerable part of your body.
- Never place your hand behind the blade. If kickback occurs, your hand will be pulled into the blade.
- Use a push stick to keep your hands farther away from the moving blade. If a kickback occurs, the push stick will most likely take the damage that your hand would have received.

Familiarize yourself with the following safety notices used in this manual:

 This means that if precautions are not heeded, it may result in minor injury and/or possible machine damage.

 This means that if precautions are not heeded, it may result in serious or possibly fatal injury.

2.0 About This Manual

This manual is provided by Powermatic covering the safe operation and maintenance procedures for Powermatic Model PM2000B & PM2000BT Cabinet Saws. This manual contains instructions on installation, safety precautions, general operating procedures, maintenance instructions and parts breakdown. Your machine has been designed and constructed to provide consistent, long-term operation if used in accordance with the instructions set forth in this document.

This manual is not intended to be an exhaustive guide to table saw operational methods, use of jigs or after-market accessories, choice of stock, etc. Additional knowledge can be obtained from experienced users or trade articles. Whatever accepted methods are used, always make personal safety a priority.

If there are questions or comments, please contact your local supplier or Powermatic. Powermatic can also be reached at our web site: www.powermatic.com.

Retain this manual for future reference. If the machine transfers ownership, the manual should accompany it.

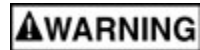

Read and understand the entire contents of this manual before attempting assembly or operation! Failure to comply may cause serious injury!

3.0 Table of Contents

Section	Page
1.0 Safety Warnings	2
2.0 About This Manual	4
3.0 Table of Contents	5
4.0 Terminology	7
5.0 Specifications	8
5.1 Kit Configurations	9
6.0 Setup and Assembly	10
6.1 Shipping Contents	10
6.2 Tools Required for Assembly	10
6.3 Unpacking and Cleanup	11
6.4 Installing Extension Wings	11
6.5 Handwheel, Knobs, Levers	12
6.6 Rails and Fence	12
6.7 Motor Cover	12
6.8 Table Insert	13
6.9 Installing and Removing Blades	13
6.10 Installing Guard/Knife Assembly	13
6.11 Dust Port	14
7.0 Electrical Connections	15
7.1 Grounding Instructions	15
7.2 Voltage Conversion (3-phase model only)	15
7.3 Extension Cords	15
7.4 Magnetic Switch and Safety Key	16
8.0 Adjustments	16
8.1 Tools Required for Adjustments	16
8.2 Fence Alignment	16
8.3 Blade Raising and Tilting	16
8.4 Caster Mechanism	17
8.5 Miter Gauge	17
8.6 Blade Tilt Stop Adjustment	18
8.7 Riving Knife Alignment	19
8.8 Table to Blade Alignment	20
8.9 Belt Adjustment	20
8.10 DRO Calibration and Operation	20
9.0 Operations	21
10.0 Safety Devices	25
10.1 Feather Board	25
10.2 Push Stick and Push Block	25
11.0 Maintenance	27
11.1 General Inspection	27
11.2 Cleaning	27
11.3 Lubrication	27
11.4 Arbor/Arbor Bearing Removal	27
11.5 Additional Servicing	27
12.0 Optional Accessories	28
13.0 Troubleshooting	29
13.1 Motor and Electrical Problems	29
13.2 Mechanical and Operational Problems	29
14.0 Replacement Parts	30
14.1.1 Table and Cabinet Assembly I – Exploded View	31
14.1.2 Table and Cabinet Assembly II – Exploded View	32
14.1.3 Table and Cabinet Assembly – Parts List	33
14.2.1 Motor and Trunnion Assembly I – Exploded View	36
14.2.2 Motor and Trunnion Assembly II – Exploded View	37
14.2.3 Motor and Trunnion Assembly – Parts List	38
14.3.1 Blade Guard Assembly – Exploded View	41
14.3.2 Blade Guard Assembly – Parts List	42
14.4.1 PM2000B Miter Gauge Assembly – Exploded View	43

14.4.2	PM2000B Miter Gauge Assembly – Parts List	43
14.5.1	PM2000BT Miter Gauge Assembly – Exploded View	44
14.5.2	PM2000BT Miter Gauge Assembly – Parts List	45
14.6.1	Motor Cover Assembly – Exploded View	46
14.6.2	Motor Cover Assembly – Parts List	46
15.0	Electrical Connections	47
15.1	Wiring Diagram – 3HP, 230V, 1PH	47
15.2	Wiring Diagram – 5HP, 230V, 1PH	48
15.3	Wiring Diagram – 5HP, 230V, 3PH	49
15.4	Wiring Diagram – 5HP, 460V, 3PH	50
16.0	Warranty and Service	51

4.0 Terminology

Arbor: Metal shaft that connects the drive mechanism to the blade.

Bevel Edge Cut: Tilt of the saw arbor and blade between 0° and 45° to perform an angled cutting operation.

Blade Guard: Mechanism mounted over the saw blade to prevent accidental contact with the cutting edge.

Crosscut: Sawing operation in which the miter gauge is used to cut across the grain of the workpiece.

Dado Blade: Blade(s) used for cutting grooves and rabbets. A stacked dado set can be used for wider grooves.

Dado Cut: Flat bottomed groove in the face of the workpiece made with a dado blade.

Featherboard: Device used to keep a board against the rip fence or table that allows the operator to keep hands away from saw blade.

Freehand: Moving the workpiece into the blade using only the hands, without a fixed positioning device. (This is a dangerous, unacceptable procedure – **always** use appropriate devices to feed the workpiece through the saw blade during cutting operations.)

Kerf: The resulting cut or gap made by a saw blade.

Kickback: An event in which the workpiece is lifted up and thrown back toward an operator, caused when a workpiece binds on the saw blade or between the blade and rip fence (or other fixed object). To minimize or prevent injury from kickbacks, see the *Operations* section.

Miter Gauge: A component that controls the workpiece movement while performing a crosscut of various angles.

Non-Through Cut: A sawing operation that requires the removal of the blade guard and standard riving knife, resulting in a cut that does not protrude through the top of the workpiece (includes dado and rabbet cuts).

The blade guard and riving knife must be re-installed after performing a non-through cut to avoid accidental contact with the saw blade during operation.

Parallel: Position of the rip fence equal in distance at every point to the side face of the saw blade.

Perpendicular: 90° (right angle) intersection or position of the vertical and horizontal planes such as the position of the saw blade (vertical) to the table surface (horizontal).

Push Board/Push Stick: An instrument used to safely push the workpiece through the cutting operation by keeping the operator's hands at a distance.

Rabbet: A cutting operation that creates an L-shaped channel along the edge of the board.

Rip Cut: A cut made along the grain of the workpiece.

Riving Knife: A metal plate fixed relative to the blade, which moves with the blade as cutting depth is adjusted. Thus, it maintains not only the kerf opening in the workpiece, but also the knife-to-blade distance. A *low-profile* riving knife sits lower than the top edge of the blade, for making a non-through cut.

Splitter (Spreader): A stationary metal plate to which the blade guard is attached that maintains the kerf opening in the workpiece during a cutting operation. (Powermatic table saws use the superior riving knife system instead.)

Standard Kerf: 1/8" gap made with a standard blade.

Straightedge: A tool used to check that a surface is flat or parallel.

Through Sawing: A sawing operation in which the workpiece thickness is completely sawn through. Proper blade height usually allows 1/8" of the top of blade to extend above the wood stock. Keep the blade guard down, the anti-kickback pawls down, and the riving knife in place over the blade.

5.0 Specifications

Table 1

Model numbers	PM2000B & PM2000BT		
Stock number – saw only (see Table 2 below for kit configurations)	PM231B/PM231BT	PM251B/PM251BT	PM253B/PM253BT
Motor and Electricals			
Motor type	Totally enclosed, fan cooled, induction		
Horsepower	3 HP	5 HP	5 HP
Motor phase	1 PH		3 PH
Motor voltage	230 V		230/460 V ¹ (prewired 230 V)
Cycle	60 Hz		
Listed FLA (full load amps)	14.5 A	21 A	13 / 6.5 A
Motor speed	3450 RPM		
Starting amps	86	126	120
Running amps (no load)	4.9	4.8	6.5
Start capacitor	400MFD 125VAC	400MFD 250VAC	n/a
Run capacitor	40µF 350VAC	30µF 500VAC	n/a
Power transfer	Poly-V belt		
On/off switch	Magnetic switch, with safety key		
Power cord and plug	not supplied		
Recommended circuit size ²	20 A	30 A	20 A
Sound emission without load ³	84 db at 100cm; 89 dB at 50cm		
Arbor and blade			
Arbor diameter	5/8 in. (15.875 mm)		
Arbor speed	4500 RPM		
Arbor lock	yes		
Arbor wrench	included		
Blade included	Ø10 in. (254mm), 0.079 in. (2.0mm) thk, 0.118 in. (3.0mm) kerf, 40T, AB, carbide tips		
Maximum depth of cut at 90 degrees	3-1/8 in. (80 mm)		
Maximum depth of cut at 45 degrees	2-1/8 in. (54 mm)		
Maximum rip to right of blade	30 in. (762 mm) or 50 in. (1270 mm)		
Maximum rip to left of blade	13-1/2 in. (343 mm)		
Dado maximum width	13/16 in. (21 mm)		
Dado maximum diameter	8 in. (203 mm)		
Blade tilt	Left, 0° to 45°		
Table			
Main table dimensions, L x W	30-1/2 x 22 in. (775 x 559 mm)		
Table dimensions with extensions, L x W	30-1/2 x 42 in. (775 x 1067 mm)		
Table area in front of blade at maximum height	11-1/4 in. (286 mm)		
Table surface from floor, casters disengaged	35 in. (889 mm)		
Miter T-slot, W x D	2 slots; 3/4 x 3/8 in. (19 x 10 mm)		
Edge bevel	Front and rear		
Dust collection			
Dust port outside diameter	4" (101.6 mm)		
Recommended minimum extraction volume	400 CFM (0.5 CMM)		

Main materials			
Main table (PM2000B)	cast iron		
Main table (PM2000BT)	cast iron with industrial-grade low-friction coating		
Table insert	aluminum		
Extension wings (PM2000B)	cast iron		
Extension wings (PM2000BT)	cast iron with industrial-grade low-friction coating		
Cabinet	steel		
Base	steel		
Center trunnion	cast iron		
Bearing arm	cast iron		
Pulleys	steel		
General Dimensions			
Base footprint	23 x 28 in. (584 x 711 mm)		
Assembled, w/ extension wings only, L x W x H	42-5/8 x 32-3/4 x 40-3/8 in. (1083 x 832 x 1026 mm)		
Assembled, with 30-in. rail set, L x W x H	66-3/4 x 39-1/8 x 40-3/8 in. (1694 x 993 x 1026 mm)		
Assembled, with 50-in. rail set, L x W x H	84-3/4 x 39-1/8 x 40-3/8 in. (2151 x 993 x 1026 mm)		
Caster elevation (approximate)	3/4 in. (19 mm)		
Shipping dimensions, saw only, L x W x H	29-7/8 x 33 x 43-1/2 in. (760 x 840 x 1105 mm)		
Weights			
Saw only – net weight	385 lb. (175 kg)	405 lb. (184 kg)	398 lb. (181 kg)
Saw only – shipping weight	535 lb. (243 kg)	555 lb. (252 kg)	548 lb. (249 kg)

¹ Note: For 460V operation, an overload relay (Part No. PM2000B-2107BORA) must be purchased separately and installed. A qualified electrician is recommended.

² subject to local/national electrical codes.

³ The specified values are emission levels and are not necessarily to be seen as safe operating levels. As workplace conditions vary, this information is intended to allow the user to make a better estimation of the hazards and risks involved only.

L = length, W = width, H = height, D = depth

n/a = not applicable

5.1 Kit Configurations

	Stock numbers		
Saw only	PM231B	PM251B	PM253B
Saw with 30-inch rail set, wood ext table	PM23130K	PM25130K	PM25330K
Saw with 50-inch rail set, wood ext table	PM23150K	PM25150K	PM25350K
Saw with 50-inch rail set & router lift	PM23150RK	PM25150RK	PM25350RK
Saw with 50-inch rail set & workbench	PM23150WK	PM25150WK	PM25350WK

	Stock numbers		
Saw only	PM231BT	PM251BT	PM253BT
Saw with 30-inch rail set, wood ext table	PM23130KT	PM25130KT	PM25330KT
Saw with 50-inch rail set, wood ext table	PM23150KT	PM25150KT	PM25350KT
Saw with 50-inch rail set & router lift	PM23150RKT	PM25150RKT	PM25350RKT
Saw with 50-inch rail set & workbench	PM23150WKT	PM25150WKT	PM25350WKT

Table 2

The specifications in this manual were current at time of publication, but because of our policy of continuous improvement, Powermatic reserves the right to change specifications at any time and without prior notice, without incurring obligations.

6.0 Setup and Assembly

⚠ WARNING Read and understand all assembly instructions before attempting assembly.

⚠ WARNING The saw must be disconnected (unplug!) from power during assembly. Failure to comply may cause serious injury.

6.1 Shipping Contents

See Figure 6-1.

Remove all accessory boxes from shipping pallet. Remove items from inside cabinet. Do not discard any packing material until saw is assembled and running satisfactorily.

Compare contents of your container with parts list below to make sure all parts are intact. Any missing parts should be reported to your distributor. (Check saw first in case parts were preinstalled.)

- 1 Cabinet saw with switch – A
- 2 Cast iron extension wings – B
- 1 Miter gauge assembly – C
- 1 Motor cover with hinge pins – D
- 1 Push stick – E
- 1 Arbor wrench – F
- 1 Caster elevating handle – G
- 2 Handles – H
- 1 Handwheel – J
- 1 Handwheel lock knob – K
- 1 Blade guard – L
- 1 Low profile riving knife – M
- 1 Riving knife – N
- 1 Anti-kickback pawl assembly – O
- 1 Table insert (preinstalled) – P
- 1 Blade (preinstalled)
- 1 Product registration card
- 1 Operating Instructions and Parts Manual
- 1 Hardware package

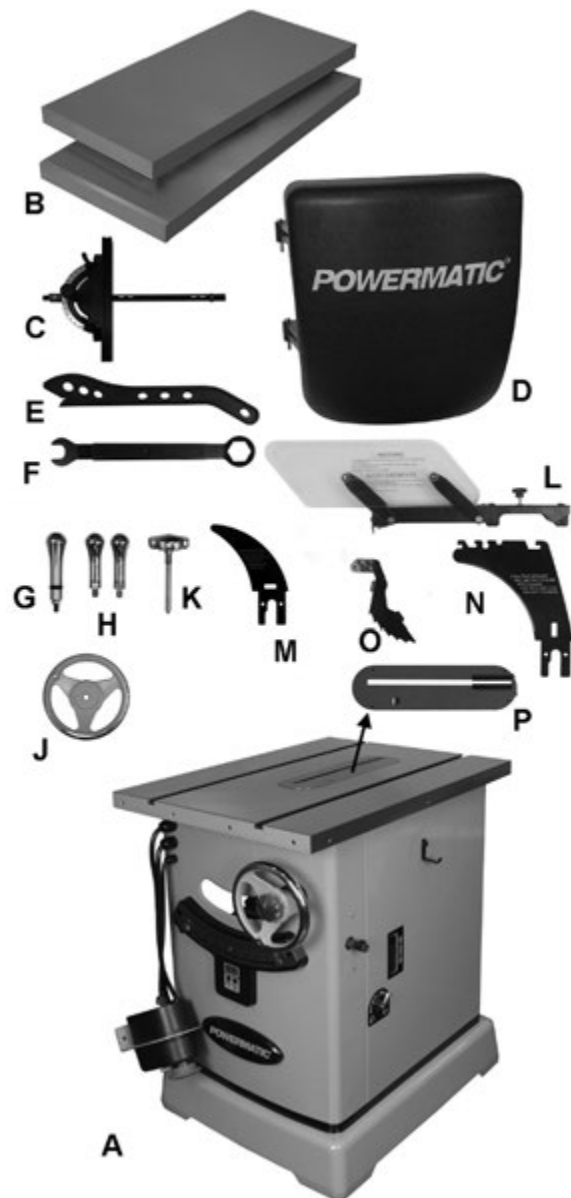

Figure 6-1 (items not to scale)

6.1.2 Hardware Package #PM2000B-HP

See Figure 6-2.

- 6 Hex cap screws, M10x35 (HP1)
- 6 Lock washers M10 (HP2)
- 6 Flat washers M10 (HP3)

NOTE: Fence and rail assemblies with fasteners, and wood extension tables and legs with fasteners, are shipped in separate boxes.

6.2 Tools Required for Assembly

- Hex key 2.5mm
- Open end wrenches: 14mm, 17mm
- Straight edge
- Rubber mallet (or hammer with block of wood)

Note: A ratchet wrench with sockets will speed assembly time. Additional tools may be needed for assembly of fence and rails.

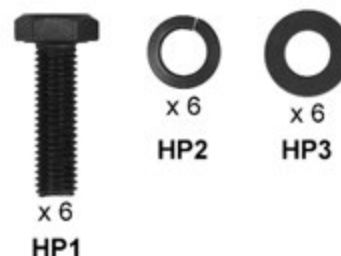

Figure 6-2 hardware package (PM2000B-HP)

6.3 Unpacking and Cleanup

CAUTION Model PM2000BT has an industrial-grade low-friction corrosion-resistant coating on the table and table extensions. While the coating is durable, it can be damaged if metal or other hard and/or sharp objects strike, gouge, or scratch the surface. Significant damage to the coating may affect its performance. Use care when unpacking and locating the machine.

1. Use a hoist to lift saw off pallet; or remove nailed boards holding saw cabinet to pallet and slide saw off pallet onto floor. (Be careful not to damage caster system while sliding it off pallet.)
2. The cabinet saw should be placed in an area with a sturdy level floor, good ventilation, and sufficient lighting. Leave enough space around the machine for mounting extension tables and rail assemblies and loading and off-loading stock and general maintenance work.
3. Exposed metal surfaces, such as table top and extension wings, have been given a protective coating at the factory. This should be removed with a soft cloth moistened with kerosene or a cleaner-degreaser. Do not use acetone, gasoline, or lacquer thinner for this purpose. Do not use solvents on plastic parts and avoid using an abrasive pad as it may scratch surfaces. **Note: Model PM2000BT has an industrial-grade low-friction corrosion-resistant coating on the table top and table extensions and will not require cleaning.**

6.4 Installing Extension Wings

See Figure 6-3.

1. Mating edges of table and wings should be clean and free of burrs.
2. Attach an extension wing (B) to saw table. (Extension wings are identical). Use three screws, lock washers and flat washers (HP-1/2/3). Lightly snug screws with 17mm wrench or socket. *Do not fully tighten yet.*

Assembly Tip: If you are doing this without an assistant, lift extension wing perpendicular to table edge. Install center screw and washers and make snug. Then pivot wing parallel to saw table to insert remaining two screws.

3. Repeat for opposite extension wing. Lightly snug screws. *Do not fully tighten yet.*
4. The front edge of extension wings must be flush with front edge of saw table. If needed, tap front edge of wing with a rubber mallet to make flush. See Figure 6-4.

6.4.1 Leveling Extension Wings

Level extension wings to saw table using a straight edge. A metal straight edge is ideal, though a carefully jointed board may also be used.

Two methods are described below: one using a rubber mallet, the other using clamps on the table edges.

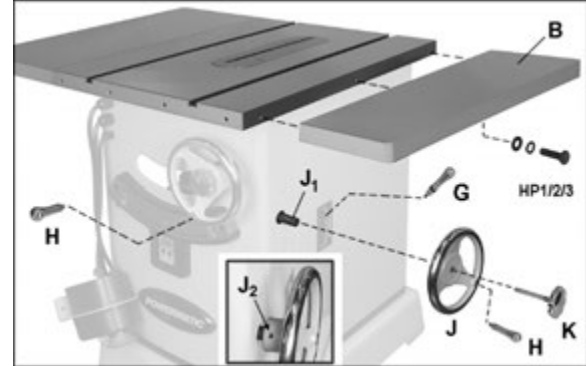

Figure 6-3: installing accessories

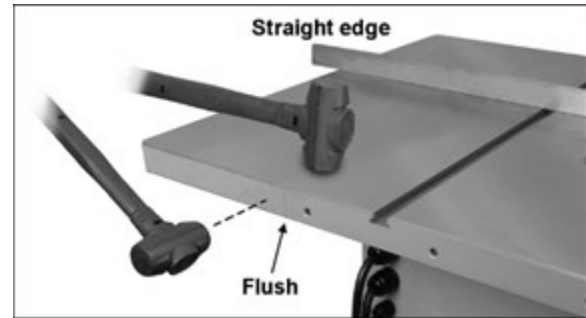

Figure 6-4: leveling extension wings, method 1

Method 1 (Figure 6-4):

1. Shift extension wing so it is slightly above saw table surface.
2. Begin by tightening the three screws beneath extension wing that secure it to saw table. Tighten these just enough to hold wing in place but loose enough to change wing height by tapping on it. (Tap with rubber mallet, or hammer over a flat block of wood. Never use a steel-faced hammer directly on the tables.)
3. Lay straight edge across saw table and extension wing, extending it out past edge of wing as shown in Figure 6-4.
4. Move straight edge to several places along wing, as you continue to nudge wing level with saw table. Also brush your fingertips over the seam to ensure the transition feels smooth. As each area of wing becomes flush with table, tighten screw under that area. Continue until all three screws are fully tightened. **NOTE:** Make sure front edge of wing remains flush with front edge of saw table.
5. Repeat above steps for opposite extension wing.

Method 2 (Figure 6-5):

1. Follow steps 1 through 3 from Method 1.
2. Position clamps over seam, one at front, one at back of table. Use a pad or flat block beneath clamp jaw to prevent damage to table surface. See Figure 6-5.
3. Tighten both clamps to align front and back edges of tables. Make sure front edge of wing remains flush with front edge of saw table.
4. Tighten screws incrementally, and position straight edge at various places across seam, especially checking at the center. Make further adjustments as needed.
5. Fully tighten screws.



Figure 6-5: leveling extension wings, method 2

6.5 Handwheel, Knobs, Levers

See Figure 6-3.

1. Remove tape from around shaft to expose threads and shaft key (J₁, Figure 6-3).
2. Ensure that set screw in handwheel (J₂) is backed out sufficiently to prevent interference.
3. Ensure that key is in slot. Slide handwheel onto shaft, aligning keyway with key.
4. Push handwheel on shaft as far as it will go, then tighten set screw (J₂).
5. Install locking knob (K, Figure 6-3) and handles (H). Use wrench on flat of handles to tighten against handwheels.

6.6 Rails and Fence

With extension wings properly mounted, the rails and Accu-Fence® assembly can now be mounted to saw. Consult manual no. M-2195079B which accompanies the fence, then proceed with *sect. 6.7* below.

6.6.1 Switch Bracket

See Figure 6-6.

The switch bracket is installed at the same time as guide tube. Use two screws with washers which are provided with the rails.

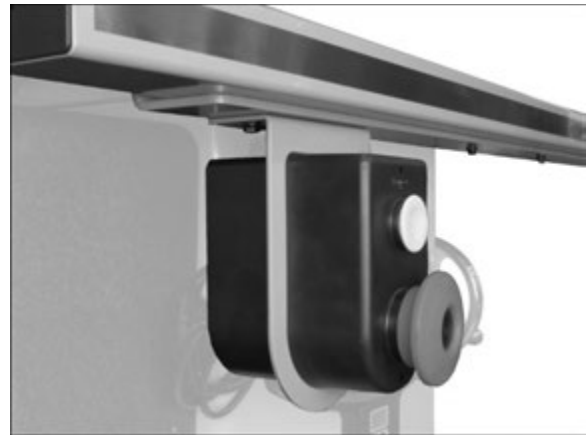

Figure 6-6: installing switch

6.6.2 Wood Extension Table

For instructions on mounting the accessory wood extension table, consult Accu-Fence manual, no. M-2195079B.

6.7 Motor Cover

See Figure 6-7.

Slide pins of motor cover into hinge barrels on saw. Close motor cover until it catches on post on saw.

Note: The catch mechanism may require adjustment to ensure proper closure. Loosen screw and position as needed. Retighten screw.



Figure 6-7: installing motor cover

6.8 Table Insert

See Figure 6-8.

CAUTION Model PM2000BT has an industrial-grade low-friction corrosion-resistant coating on the table and table extensions. While the coating is durable, it can be damaged if metal or other hard and/or sharp objects strike, gouge, or scratch the surface. Significant damage to the coating may affect its performance. Use care when using a metal straight edge to verify insert is flush with the table surface.

Place insert into table opening. Verify that insert lies flush with table surface by resting a straight edge across it at various points. If insert is not flush along its length, turn any of 4 set screws to raise or lower that area of insert.

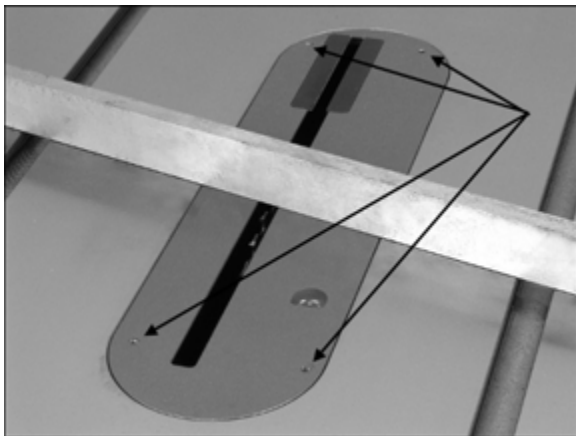

Figure 6-8: leveling table insert

6.9 Installing and Removing Blade

CAUTION Model PM2000BT has an industrial-grade low-friction corrosion-resistant coating on the table and table extensions. While the coating is durable, it can be damaged if metal or other hard and/or sharp objects strike, gouge, or scratch the surface. Significant damage to the coating may affect its performance. Use care when installing and removing saw blade.

CAUTION Use caution when working with or near sharp saw blades to prevent injury.

See Figure 6-9.

1. Disconnect machine from power source.
2. Remove table insert.
3. Raise blade arbor to highest position and set blade tilt to 0°.
4. Install blade onto arbor, making sure teeth point downward toward front of saw.

5. Install flange and nut as shown.
6. Press down and hold lever (R, Figure 6-9), and rotate blade until arbor lock engages. Tighten nut clockwise with provided arbor wrench. Do not overtighten nut.

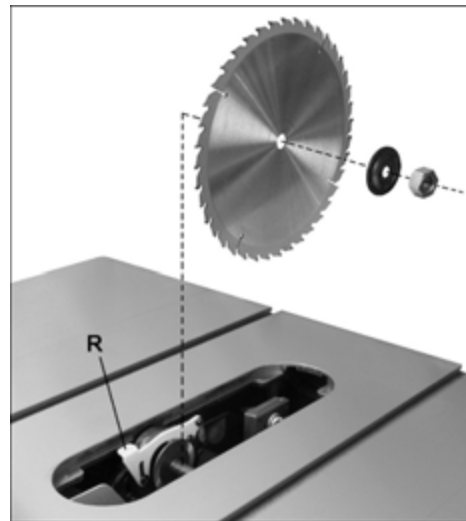

Figure 6-9: installing blade

7. To remove blade, engage arbor lock and remove nut with wrench.

6.10 Installing Guard/Knife Assembly

See Figure 6-10.

6.10.1 Riving Knife

1. Remove table insert.
2. Raise blade arbor to highest position and set blade tilt to 0°.
3. Pull clamp lever (S₁, Figure 6-9) upward. The clamp plate (S₂) is spring loaded and will move away from the fixed base, leaving a gap.

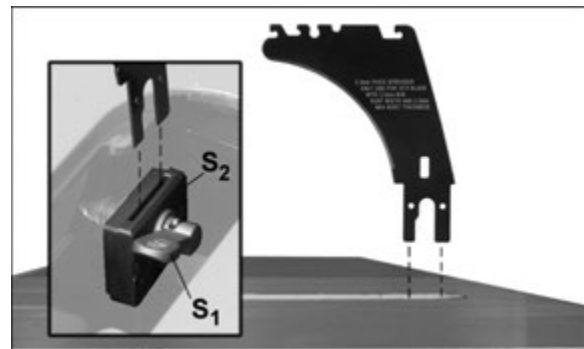

Figure 6-10: installing guard assembly

4. Slide prongs of riving knife (N) into slot on clamping base, and push riving knife down as far as it will go.
5. Push clamp lever (S₁) down to closed position.
6. Riving knife must be parallel to saw blade. See sect. 8.7 for inspection and adjustments.

NOTE: A low-profile riving knife is also provided, for making non-through cuts on the table saw.

6.10.2 Anti-Kickback Pawls

See Figures 6-11 and 6-12.

1. Install insert plate into table.
2. Push and hold button (O₁) on opposite side of the head to release the catch pin. Mount pawl assembly straight down, in the location shown in Figure 6-11.
3. Pivot head and push it downward (Figure 6-12) until there is an audible click. *Make sure you hear the click to verify that pawl assembly is secure.*

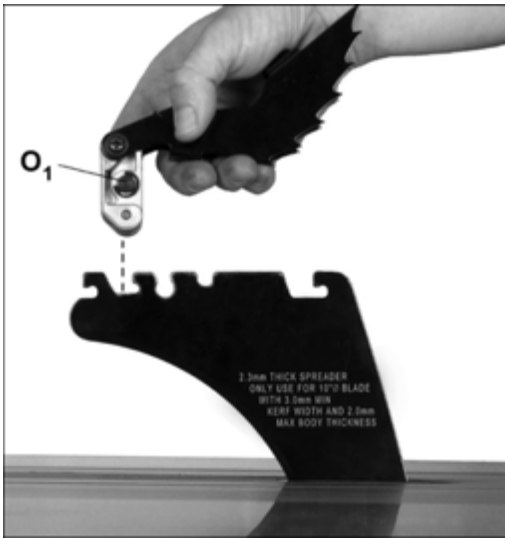

Figure 6-11



Figure 6-12

6.10.3 Blade Guard

See Figure 6-13.

1. Push up guard leaves (E, Figure 6-12) until they catch and hold on the peg (F).

2. Lower blade guard assembly onto riving knife and push it backward to seat it.
3. Tighten knob (G).
4. Pull down guard leaves (E) and allow them to drop to the table.
5. Reverse procedure to remove guard.

IMPORTANT: Knob (G) must be tightened before operating saw with guard in place.

WARNING Guard, riving knife, and pawl assemblies must be securely installed, and leaves must be in contact with table, before beginning any through-cutting operation.

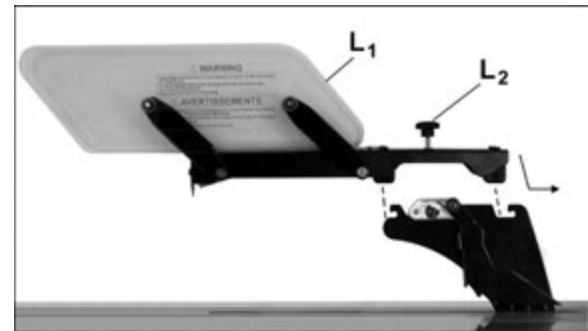

Figure 6-13

The riving knife clamping base is adjusted by the manufacturer and no further adjustment of blade guard and riving knife assembly should be necessary. However, **proper alignment is very important.** Before operating table saw, read sect. 8.7, *Riving knife alignment*, to verify and follow adjustment procedure if necessary.

6.11 Dust Port

Use of a dust collection system (not provided) is strongly recommended during table saw operation. It will help keep the shop clean, as well as prevent potential health issues due to dust inhalation.

Make sure internal hose is pushed into external dust port (Figure 6-14). Attach hose from your dust collection system to the 4-inch dust port at base of saw, and secure with wire hose clamp (not provided).



Figure 6-14

7.0 Electrical Connections

⚠WARNING Electrical connections must be made by a qualified electrician in compliance with all relevant codes. This machine must be properly grounded to help prevent electrical shock and possible fatal injury.

A power plug is not provided with this table saw. You may either connect the proper UL/CSA listed plug or “hardwire” the machine directly to your electrical panel provided there is a disconnect near the machine for the operator. Consult electrical drawings in *sect. 15.0* for further clarification of wiring setup.

Before connecting to power source, be sure switch is in *off* position.

It is recommended that the 3HP 1-phase, and 5HP 3-phase table saws be connected to a dedicated **20-amp** circuit with breaker or fuse.

The 5HP 1-phase saw should be connected to a **30-amp** circuit with breaker or fuse.

If connected to a circuit protected by fuse, use time delay fuse marked “D”. **Local codes take precedence over recommendations.**

7.1 Grounding Instructions

This machine must be grounded. In the event of a malfunction or breakdown, grounding provides a path of least resistance for electric current to reduce the risk of electric shock. This tool is equipped with an electric cord having an equipment-grounding conductor. A plug is not provided. A proper UL/CSA listed plug may be installed or the machine may be “hard-wired” to a circuit panel. If hard-wired, make sure a disconnect is available to the operator.

Improper connection of the equipment-grounding conductor can result in a risk of electric shock. The conductor with insulation having an outer surface that is green with or without yellow stripes is the equipment-grounding conductor. If repair or replacement of the electric cord or a plug is necessary, do not connect the equipment-grounding conductor to a live terminal.

⚠WARNING Check with a qualified electrician or service personnel if the grounding instructions are not completely understood, or if in doubt as to whether the tool is properly grounded. Failure to comply may cause serious or fatal injury.

Repair or replace damaged or worn cord immediately.

7.2 Voltage Conversion (3-phase model only)

1. Remove transformer cover at back of machine and move fuse from 230V position to 460V position on transformer.
2. Switch the incoming power leads to the motor for 460-volt operation, according to wiring diagram on inside cover of motor junction box. A similar diagram is found in *sect. 15.0* of this manual. (*In case of discrepancy, diagram in junction box takes precedence.*)
3. Replace the 230V overload relay with a 460V overload relay (additional purchase, part number PM2000B-2107BORA).
4. If using a plug, the 230V plug must be replaced with a UL/CSA listed plug rated for 460V.

7.3 Extension Cords

USE PROPER EXTENSION CORD. Make sure your extension cord is in good condition. When using an extension cord, be sure to use one heavy enough to carry the current your product will draw. An undersized cord will cause a drop in line voltage resulting in loss of power and overheating. Table 3 shows correct size to use depending on cord length and nameplate ampere rating. If in doubt, use the next heavier gauge. The smaller the gauge number, the heavier the cord.

Amp Rating		Volts	Total length of cord (ft.)			
More Than	Not More Than		50	100	200	300
		240	AWG			
0	6		18	16	16	14
6	10		18	16	14	12
10	12		16	16	14	12
12	16		14	12	Not Recommended	

Table 3: extension cord recommendations

7.4 Magnetic switch and Safety Key

Refer to Figure 7-2.

Power Indicator Light – The start switch has a power indicator lamp which is on *whenever there is power connected* to the saw, not just when the saw is running. Always check before use.

⚠WARNING Do not assume that no light means there is no power to the machine. If the bulb is bad, there will be no indication. Always check for power first. Failure to comply may cause serious injury!

To Start – Press green start switch.

When power is connected to the machine, the green light is always on regardless of whether the saw is running or not.

To Stop – Press red switch to stop.

Reset – If the saw stops without pressing the stop button, as the result of a tripped fuse or circuit breaker:

1. Press red button to reset.
2. Press green button to restart machine.

7.4.1 Safety Key

The switch is equipped with a magnetic safety key. When in place on the switch as shown in Figure 7-2, the safety key trips a relay which will allow the machine to start and stop when the respective switches are pressed. Being magnetic, the key can be removed to make the machine inoperable and can be hidden for safe storage by attaching it underneath the rail or another magnetic surface.

When using the saw, place the key on the switch cover lining up the arrow on the key with the REMOVE arrow on the cover. Then rotate the key so the arrow lines up with the LOCK arrow. This prevents the safety key from vibrating loose when machine is in use.

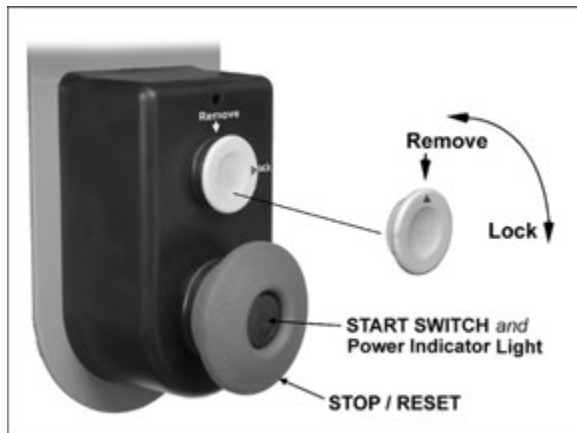

Figure 7-2

8.0 Adjustments

⚠CAUTION Model PM2000BT has an industrial-grade low-friction corrosion-resistant coating on the table and table extensions. While the coating is durable, it can be damaged if metal or other hard and/or sharp objects strike, gouge, or scratch the surface. Significant damage to the coating may affect its performance. Use care when making adjustments to this saw.

8.1 Tools Required for Adjustments

Hex keys: 2.5mm, 3mm, 4mm
Wrenches: 13mm, 19mm, 22mm (or adjustable)
Straight edge
Square

8.2 Fence Alignment

Before using the Accu-Fence®, verify that it is properly aligned with the blade. Consult manual no. M-2195079B that accompanied the fence.

8.3 Blade Raising and Tilting

See Figure 8-1.

To raise or lower blade, loosen lock knob (A, Figure 8-1) and turn handwheel (B) on front of saw until desired height is reached. Tighten lock knob (A). The blade should be raised about 1/8" above top surface of material being cut.

To tilt blade, loosen lock knob (C) and turn handwheel (D) until desired angle is obtained, as shown on tilt scale or DRO. Retighten lock knob (C).

The DRO, or digital readout (E) displays the angle for quick positioning. See sect. 8.10 for calibration of the DRO.

Reference pointers (F) can be positioned at any point along scale; loosen knob and slide pointer to position, then tighten knob. These provide a quick reference point for aligning the angle indicator.



Figure 8-1: blade adjustments

8.4 Caster Mechanism

To engage caster system, pump handle (G, Figure 8-1) about 4 or 5 times.

Disengage caster system by turning handle (H) counterclockwise. **Casters must be disengaged before operating saw.**

Note: It is recommended that saw be lowered to resting position after being moved to desired location. If left in raised position for an extended period, saw will gradually settle back to floor – this is normal.

8.5 Miter Gauge

Refer to Figures 8-2, 8-3, 8-3B, and 8-3C.

CAUTION For model PM2000BT: The miter gauge has non-marring bottom surfaces to protect the table coating. To prevent damage to the table coating, only use the miter gauge supplied with this machine.

Setting Miter Angle (model PM2000B)

The miter gauge has rack and pinion adjustment for setting angle. To operate:

1. Slide miter gauge into table slot.
2. Loosen lock handle (H, Figure 8-2) by turning counterclockwise.
3. Pull out spring-loaded knob (J) and rotate knob until body (K) of miter gauge is at desired angle as indicated on scale.
4. Tighten lock handle (H).

Indent Settings (model PM2000B)

There are indents at 0°, 30° and 45° right and left positions. At these settings, release knob (J) to engage indent. Then tighten lock handle (H).

Note: Do not rely solely on the indents for an accurate setting. After stop rod engages at the 0°, 30° and 45° positions, make a fine adjustment with the knob (J) if necessary, setting it against the scale indicator (L).

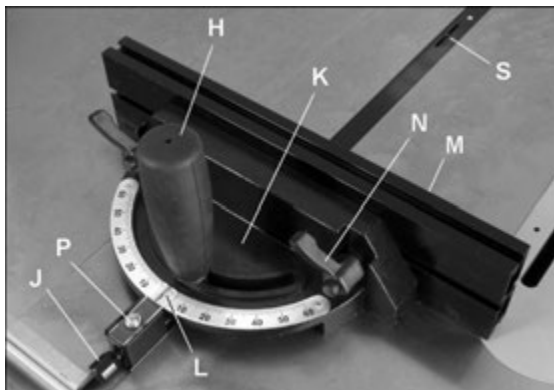

Figure 8-2

Miter Gauge Fence (model PM2000B)

The miter gauge fence (M, Figure 8-2) can be adjusted by sliding to right or left or removed entirely.

To adjust, loosen two lock handles (N), slide fence and retighten lock handles. **Make sure end of fence and lock handle are not in blade path.**

NOTE: The lock handles (N) are adjustable. Pull out on handle, rotate it to different position, then release, making sure it seats itself upon the pin.

To remove miter gauge fence, slide it completely off and remove lock handles (N) and mounting hardware.

Squaring Miter Gauge (model PM2000B)

1. Place miter gauge into table slot.
2. Set miter gauge at 90° to blade (0° setting on scale) by loosening lock handle (H, Figure 8-2), then pulling out spring-loaded knob (J) and turning body (K) until 0° is indicated on scale.
3. Measure accuracy of miter gauge against slot with a square.

If adjustment is needed:

4. Adjust body (K) until it is square (90°) to miter slot.
5. Tighten lock handle (H).
6. Verify that scale indicator (L) reads 0°. If it does not, loosen screw (P) and adjust indicator (L) until it reads 0°. Retighten screw (P).
7. If the above procedure does not satisfactorily align the miter gauge, loosen two screws (R, Figure 8-3) beneath mounting block and shift block as needed. Retighten screws when finished.

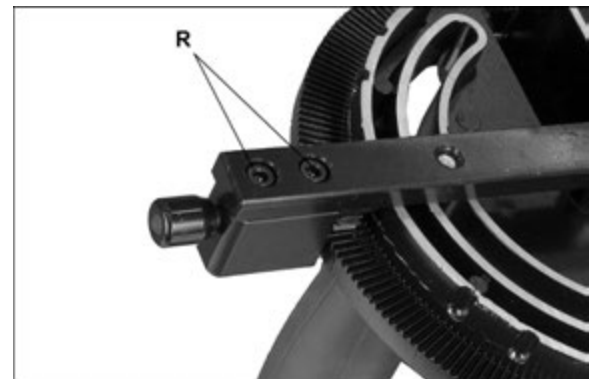

Figure 8-3

NOTE: The miter gauge bar has two slots with set screws (S, Figure 8-2). Adjust these set screws to eliminate any play between bar and miter slot.

Squaring Miter Gauge (model PM2000BT):

1. Place a square against miter gauge face, and against flat of blade. (Place square against flat of blade, not against the teeth which are set wider than the blade body).
2. Loosen screws A and B as shown in Figure 8-3C.
3. Adjust the miter gauge fence to make it square to the blade. Tighten screws A and B.
4. After squaring, if the red pointer (C) is not pointing at 0°, loosen the pointer setscrew (see Figure 8-3B), rotate the pointer to 0°, and retighten the pointer setscrew.

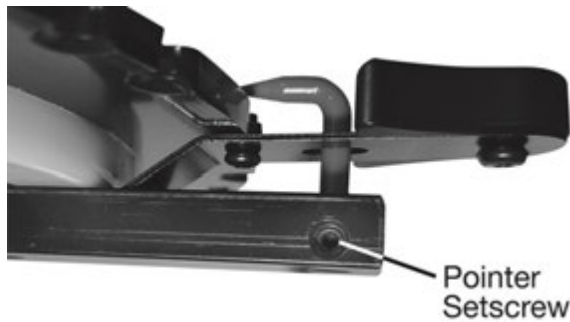

Figure 8-3B

Adjusting Miter Gauge Angle for Operations (model PM2000BT, refer to Figure 8-3C):

1. Unscrew handle (D) just enough to loosen it.
2. Press black tab (E) to release it from stop 0°.
3. Rotate gauge body until red pointer (C) lines up with desired angle on scale.
4. Tighten handle (D).
5. There are 13 stops at 0°, 15°, 22.5°, 30°, 45°, 60°, and 67.5° left and right. Each of these can be adjusted to by allowing the spring stop to lock into each location. Press black tab (E) to move past each stop location.

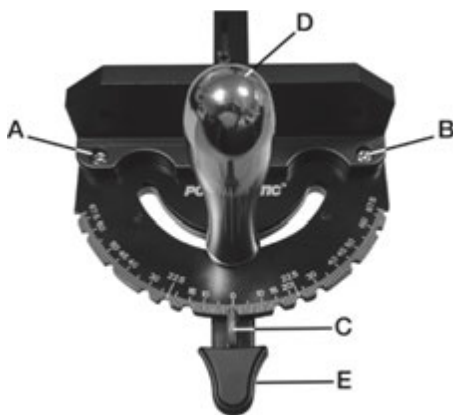

Figure 8-3C

8.6 Blade Tilt Stop Adjustment

The stops for 90°, 45° blade tilt, and elevation settings have all been factory set, and should require no immediate adjustment. The settings should be confirmed by the operator, however, and especially if cuts become inaccurate. Both tilt stops are located on the trunnion.

8.6.1 Tilt Stop 90°

1. Disconnect machine from power source.
2. Make sure table insert has been leveled with table surface (sect. 6.8).
3. Raise blade to highest position and place a square on table and against blade (Figure 8-4). Make sure that a blade tooth does not obstruct the actual reading.
4. Tilt blade with handwheel until square and blade are flush.
5. If adjustment is required, loosen nut on 90° stop screw (Figure 8-5) with 13mm wrench, and turn screw to proper height. Verify setting and retighten nut against trunnion.
6. Check pointer position on scale (Figure 8-5). If needed, loosen screw and adjust pointer to zero. Retighten screw.

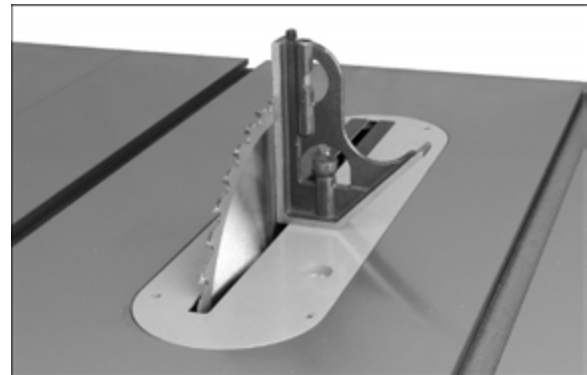

Figure 8-4

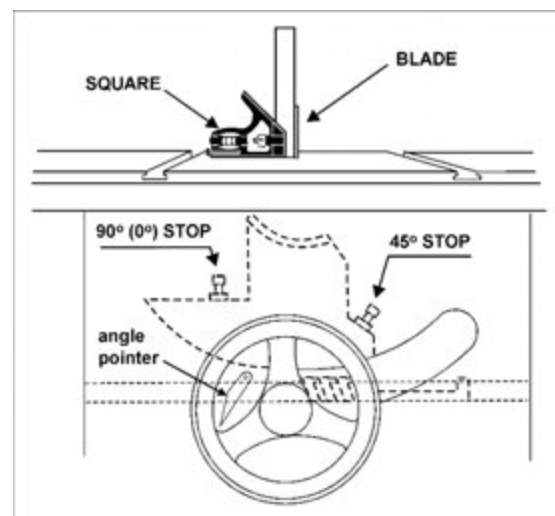

Figure 8-5: blade stops

8.6.2 Tilt Stop 45°

Follow same procedure as above, but with blade tilted at 45°, as shown in Figure 8-6.

Adjust 45° stop shown in Figure 8-5. Confirm setting, then retighten nut.

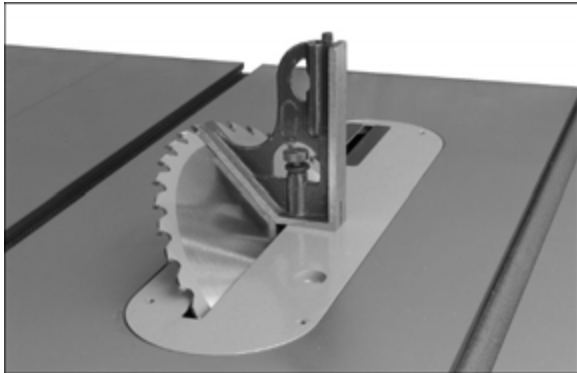

Figure 8-6

8.7 Riving Knife Alignment

8.7.1 Lateral Alignment

Saw blade and riving knife must be as closely aligned as possible (lateral alignment) for prevention of kickback. This should be checked upon initial blade guard and riving knife installation. Alignment should also be reaffirmed after each blade change.

Inspect alignment as follows:

1. Remove blade guard and pawl assembly.
2. Place a straightedge on table so it rests against blade and riving knife. See Figure 8-7. Rotate blade so that top of blade tooth touches straightedge.

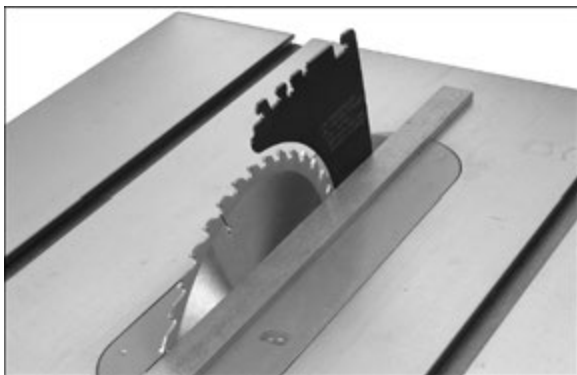

Figure 8-7

The saw blade and riving knife must be in line. If adjustment is needed:

3. Pull up lever (A, Figure 8-8) and remove riving knife, making note as to which direction riving knife needs to be moved to align it with saw blade.
4. Use 3mm hex key to make adjustments to four set screws (B, Figure 8-8). Adjust any of the set

screws required to bring riving knife in alignment with saw blade.

5. Reinsert riving knife, secure by tightening lever (A) and check alignment per step 2.
6. Repeat steps 3–5 until alignment is correct.

8.7.2 Blade Proximity Alignment

The gap between saw blade and riving knife must be between 3mm (0.12in.) and 8mm (0.32in.). See Figure 8-9.

If adjustment is needed, note whether blade-to-knife gap needs to be increased or decreased. Then adjust as follows:

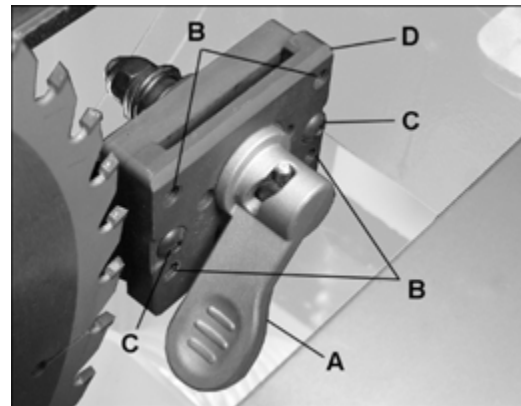

Figure 8-8

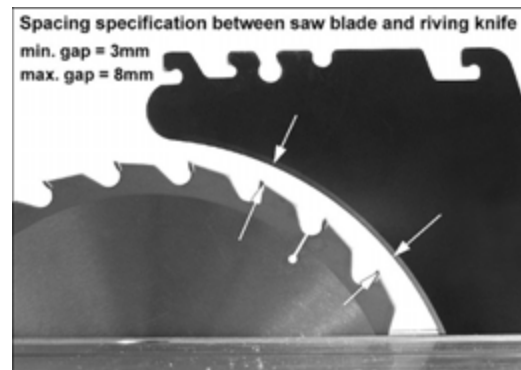

Figure 8-9

7. Remove blade guard, pawl assembly, table insert and riving knife.
8. Use 3mm hex key to loosen two socket head button screws (C, Figure 8-8). This will allow the clamp plate (D) to slide back and forth on the fixed base.

Slide clamp plate (D) toward or away from saw blade as required. Attempt to make the gaps as even as possible.
9. Tighten screws (C).
10. Reinsert riving knife; engage lever (A) and check that saw blade/knife gap is between 3-8mm (Figure 8-9).

8.8 Table to Blade Alignment

See Figures 8-10 and 8-11.

The table has been squared to the blade by the manufacturer and no adjustment should be needed now. If cuts become inaccurate, check table/blade squareness and correct if necessary.

1. Disconnect saw from power source.
2. Raise blade to maximum height.
3. Mark one tooth (A, Figure 8-10) with a grease pencil and position the tooth slightly above top edge of table at the front.
4. Raise miter gauge slightly out of its slot to serve as a shoulder. Using a sliding square (B) against the side of the bar, slide the scale over until it touches the tip of the blade, and lock scale in position.

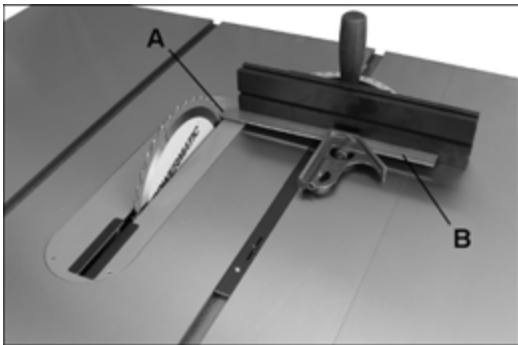

Figure 8-10

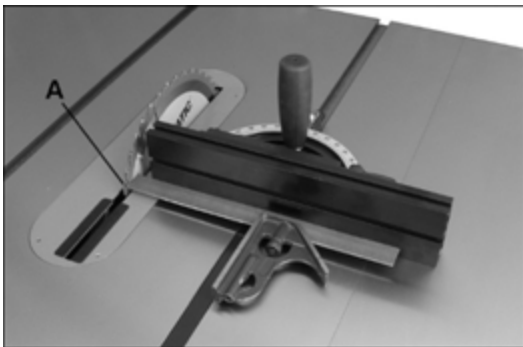

Figure 8-11

5. Rotate marked tooth (A) so that it is slightly above table top at the rear, using the square as before to verify that distance to blade is identical. See Figure 8-11. If the two distances are not the same, make a careful note of the difference.
6. Loosen table screws (*item #24, sect. 14.1.1*), and nudge table according to the distance you noted.
7. Retighten screws firmly.
8. Verify alignment, angle pointer setting, fence setting, etc. Make any needed adjustments.

8.9 Belt Adjustment

8.9.1 Belt Tension

See Figure 8-12.

Drive belt tension should be inspected after the first few days of operation, as a belt may stretch slightly during initial use; also inspect it periodically thereafter.

To tighten belt:

1. Disconnect machine from power source.
2. Loosen screw (C, Figure 8-12) with 17mm wrench.
3. Slightly loosen nut (D) with 1-1/4" (or adjustable) wrench.
4. Push motor to the right and tighten screw (C) to tension belt. Retighten nut (D). Verify proper tension by pushing on belt midway between pulleys; deflection should be about 1/2-inch.

If belt shows signs of wear, fraying, cracks, etc. it should be replaced, as follows.

8.9.2 Belt Replacement

See Figure 8-12.

1. Lower trunnion completely.
2. Loosen screw (C) with 17mm wrench.
3. Slightly loosen nut (D) with 1-1/4" (or adjustable) wrench.
4. Pivot motor to the left to release tension.
5. Replace belt.
6. Push motor to the right and tighten screw (C) to tension new belt. Retighten nut (D). Verify proper tension by pushing on belt midway between pulleys; deflection should be about 1/2-inch.

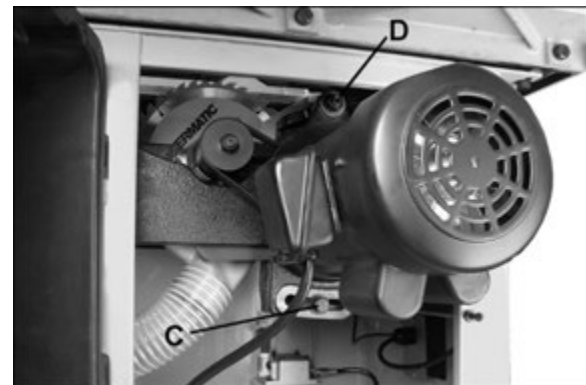

Figure 8-12

8.10 DRO Calibration and Operation

When the 0° and 45° blade tilt stops have been verified to be correct, the DRO (digital readout) can be calibrated to match the settings.

Sect. 8.10.1 describes general calibration procedure. Sect. 8.10.2 describes mandatory calibration procedures if the PCB sensor is ever replaced in the table saw.

8.10.1 General Calibration

1. Blade tilt stops must be correctly set. See sect. 8.6.
2. Connect machine to power source. DRO will be illuminated.
3. If saw blade is relatively close to 0°, set blade to exactly 0° and press “SET 0” button. Readout will display 0.00. See Figure 8-13.

Or, if saw blade is relatively close to 45°, set blade to 45°, and press “SET 45” button. Readout will display 45.0.

4. Calibration is complete.

NOTE: If power is disconnected, digital display will reset to 0.00. When power is restored, repeat above procedure.



Figure 8-13

8.10.2 PCB Replacement Calibration

1. Blade tilt stops must be correctly set. See sect. 8.6.
2. Connect machine to power source. DRO will be illuminated.
3. Tilt saw blade to 0°.
4. Press and hold both SET buttons until display shows “---” (Figure 8-14).
5. Release buttons and display will show “00.0”.
6. Calibration at 0° is complete. (If “00.0” does not display, disconnect from power, reconnect, and repeat above procedure.)
7. Tilt blade to 45°.
8. Press and hold both SET buttons until display shows “---” (Figure 8-14).
9. Release buttons and display will show “45.0”.
10. Calibration at 45° is complete. (If “45.0” does not display, disconnect from power, reconnect, and repeat above procedure.)



Figure 8-14

9.0 Operations

CAUTION Model PM2000BT has an industrial-grade low-friction corrosion-resistant coating on the table and table extensions. While the coating is durable, it can be damaged if metal or other hard and/or sharp objects strike, gouge, or scratch the surface. Significant damage to the coating may affect its performance. Use care when operating the machine.

Familiarize yourself with the location and operation of all controls and adjustments and the use of accessories such as miter gauge and rip fence.

Note: The following figures are general in nature and may not show your particular saw model.

9.1 Kickback Prevention

Serious injury can result from kickbacks which occur when a workpiece binds on the saw blade or binds between the blade and rip fence or other fixed object. This binding can cause the workpiece to lift up and be thrown toward the operator.

Listed below are conditions which can cause kickbacks:

- ❑ Confining the cutoff piece when crosscutting or ripping.
- ❑ Releasing workpiece before completing operation or not pushing workpiece all the way past saw blade.
- ❑ Not using splitter/riving knife when ripping or not maintaining alignment of splitter/ riving knife with saw blade.
- ❑ Using dull saw blade.
- ❑ Not maintaining alignment of rip fence so that it tends to angle toward rather than away from saw blade front to back.
- ❑ Applying feed force when ripping to the cutoff (free) section of workpiece instead of the section between saw blade and fence.
- ❑ Ripping wood that is twisted (not flat), or does not have a straight edge, or has twisted grain.

To minimize or prevent injury from kickbacks:

- ❑ Avoid conditions listed above.
- ❑ Wear a safety face shield, goggles, or safety glasses.
- ❑ Do not use miter gauge and rip fence in the same operation unless provision is made by use of a facing board on the fence, to allow the cutoff section of workpiece to come free before the actual cut begins (See Figure 9-8).
- ❑ As the machine receives use, the operation of the anti-kickback pawls should be checked periodically (Figure 9-1). If the pawls do not stop the reverse motion of a workpiece, resharpen all the points.

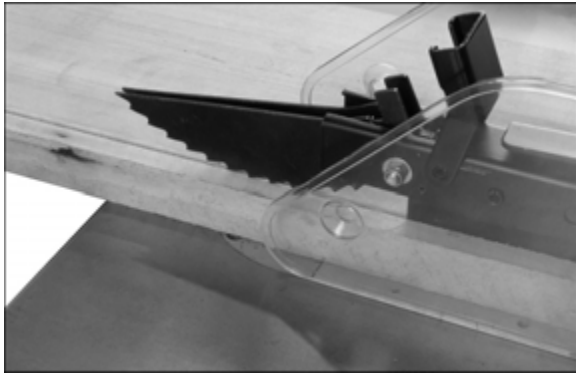

Figure 9-1

- ❑ Where possible, keep your face and body out of line with potential kickbacks, including when starting or stopping the machine.
- ❑ Dull, badly set, improper, or improperly filed cutting tools, and cutting tools with gum or resin adhering to them can cause accidents. Never use a cracked saw blade. The use of a sharp, well maintained, and correct cutting tool for the operation will help avoid injuries.
- ❑ Support the work properly and hold it firmly against gauge or fence. Use a push stick or push block when ripping short, narrow (6" width or less), or thin work. Use a push block or miter gauge hold-down when dadoing or molding.
- ❑ Never use the fence as a length stop when crosscutting. Do not hold or touch the free end or cutoff section of a workpiece. On through-sawing operations, the cutoff section must NOT be confined.
- ❑ Always keep your hands out of line of the saw blade and never reach back of the cutting blade with either hand to hold the workpiece.
- ❑ Bevel ripping cuts should always be made with the fence on the right side of saw blade so that the blade tilts away from the fence and minimizes possibility of the work binding and the resulting kickback.

9.2 Rip Sawing

Ripping is feeding the workpiece with the grain into the saw blade using the fence or other positioning device as a guide to ensure desired width of cut (Figure 9-2).

⚠ WARNING Always use a push stick or similar device when ripping narrow pieces.

⚠ WARNING Before starting a rip cut, verify that fence is clamped securely and aligned properly.

- ❑ Never rip freehand or use miter gauge in combination with the fence.
- ❑ Never rip workpieces shorter than the saw blade diameter.
- ❑ Never reach behind the blade with either hand to hold down or remove the cutoff piece with the saw blade rotating.



Figure 9-2

Always use blade guard, splitter/riving knife and anti-kickback pawls. Make sure splitter/riving knife is properly aligned. When wood is cut along the grain, the kerf tends to close and bind on the blade and kickbacks can occur.

Note: A warning decal is affixed to the guard to remind the operator of some basic safety procedures.

The rip fence should be set for the width of the cut by using the scale on the front rail, or by measuring the distance between blade (A) and fence (B). Stand out of line with saw blade and workpiece to avoid sawdust and splinters coming off the blade or a potential kickback.

If the workpiece does not have a straight edge, nail an auxiliary straight edged board on it to provide one against the fence. To cut properly, the board must make good contact with the table. Do not attempt to cut warped boards.

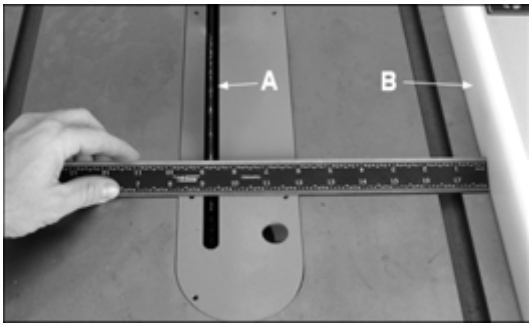

Figure 9-3

In ripping, use one hand to hold the board down against the fence or fixture, and the other to push it into the blade between blade and fence. If workpiece is narrower than 6" or shorter than 12", use a push stick or push block to push it through between fence and blade (Figure 9-4). Never push in a location such that the pushing hand is in line with the blade. Move the hand serving as a hold-down a safe distance from blade as cut nears completion.

For very narrow ripping where a push stick cannot be used, use a push block or auxiliary fence. Always push the workpiece completely past the blade at the end of a cut to minimize the possibility of a kickback.

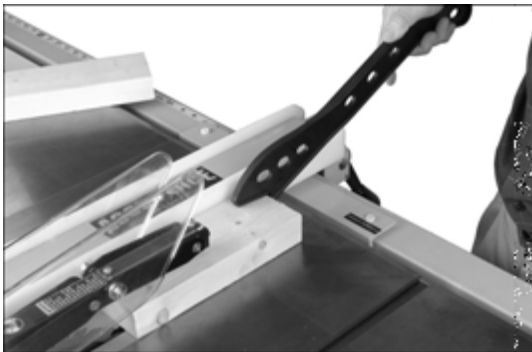

Figure 9-4

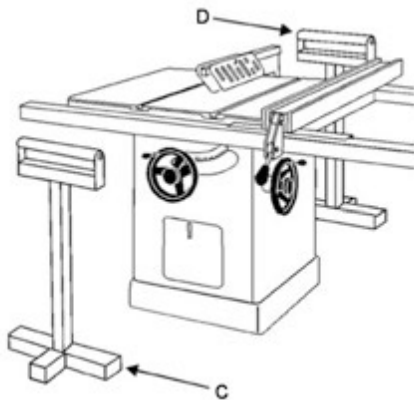

Figure 9-5

When ripping long boards, use a support at front of table (C, Figure 9-5), such as a roller stand, and a support or "tailman" at the rear (D).

Never use the rip fence beyond the point where the carriage is flush with the end of the rails.

Have the blade extend about 1/8" above top of workpiece. Exposing the blade above this point can be hazardous.

9.3 Resawing

Resawing is a ripping operation in which thick boards are cut into thinner ones. Note: A band saw is the ideal tool for resawing.

WARNING If the table saw is used for resawing, take precautions such as using an auxiliary fence, resaw barrier or similar devices to stabilize the workpiece and provide operator safety.

Narrow boards up to 3" can be resawn in one pass. Wider boards up to 6" must be resawn in two passes.

In resawing wider boards, adjust the blade height so as to overlap the two cuts by 1/2" as shown in Figure 9-6. Too deep a first cut can result in binding and possible kickbacks on the second cut. Always use the same side of the board against the fence for both cuts.

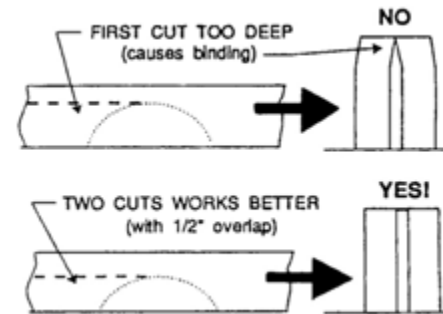

Figure 9-6

9.4 Crosscutting

Crosscutting is where the workpiece is fed cross grain into the saw blade using the miter gauge to support and position the workpiece (Figure 9-7).



Figure 9-7

Crosscutting should **never** be done freehand, nor should the fence be used as an end stop unless an auxiliary block (E, Figure 9-8) is clamped to the front

of the blade area such that the cutoff piece comes free of the block before cutting begins.

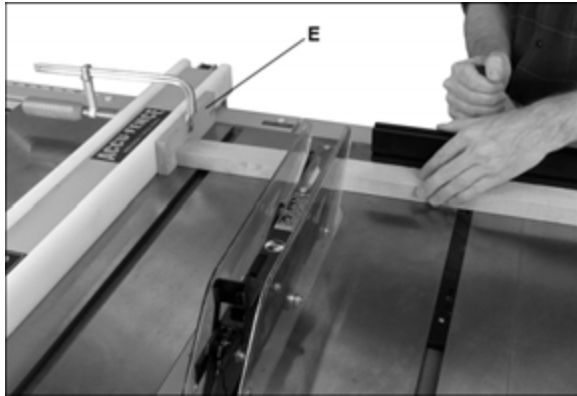

Figure 9-8

Length stops should not be used on the free end of the workpiece in the cutoff area.

Do **not** crosscut workpieces shorter than 6". Before starting a cut, be sure the miter gauge is securely clamped at the desired angle. Hold the workpiece firmly against the table and back against the miter gauge. **Always** use the saw guard and riving knife and make sure the riving knife is properly aligned.

For 90-degree crosscutting, most operators prefer to use the left-hand miter gauge slot. When using it in this position, hold the workpiece against the gauge with the left hand and use the right hand to advance the workpiece. When using the right-hand slot for miter and compound crosscutting so that the blade tilts away from the gauge, the hand positions are reversed.

When using the miter gauge, the workpiece must be held firmly and advanced smoothly at a slow rate. If the workpiece is not held firmly, it can vibrate causing it to bind on the blade and dull the saw teeth.

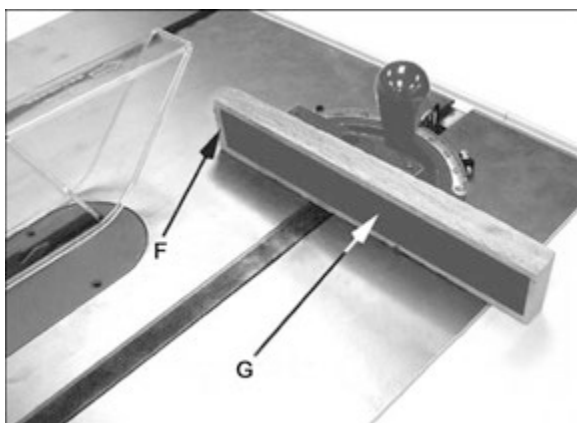

Figure 9-9

To augment the effectiveness of the miter gauge in crosscutting, some users mount an auxiliary wood extension face (F, Figure 9-9) with a glued-on strip of sandpaper (G) to help grip the workpiece.

Provide auxiliary support for any workpiece extending beyond the table top with a tendency to sag and lift up off the table.

Have the blade extend about 1/8" above the top of the workpiece. Exposing the blade above this point can be hazardous.

9.5 Bevel and Miter Operations

Bevel cut – A bevel cut is a special type of operation where the saw blade is tilted at an angle less than 90-degrees to the table top (Figure 9-10). Operations are performed in the same manner as ripping or crosscutting, except the fence or miter gauge should be used on the right-hand side of the blade to provide added safety in avoiding a binding action between blade and table top. When beveling with the miter gauge, the workpiece must be held firmly to prevent creeping.

CAUTION Never use a zero-clearance insert with saw blade in tilted position.



Figure 9-10

Mitering – Crosscuts made at an angle to the edge of the workpiece are called miters (Figure 9-11). Set the miter gauge at the required angle and make the cut the same as a normal crosscut except the workpiece must be held extra firmly to prevent creeping.



Figure 9-11

Note: When making compound miters (with blade tilted) use the miter gauge in the **right-hand** slot to provide more hand clearance and safety.

Have the blade extend only 1/8" above the top of the workpiece. Exposing the blade above this point can be hazardous.

9.6 Dado Cutting

Dadoing is cutting a wide groove into a workpiece or cutting a rabbet along the edge of a workpiece. A dado insert (optional accessory, shown in Figure 9-12) is necessary for this type of operation.

CAUTION Do not use the standard table insert for dadoing operations.



Figure 9-12

The process of cutting 1/8" to 13/16" grooves in workpieces is accomplished by the use of a stacked dado blade set or an adjustable-type blade mounted on the saw arbor. By using various combinations of stacked dado blades, or properly setting the dial on an adjustable blade, an accurate width dado can be made. This is very useful for shelving, making joints, tenoning, etc.

The guard, riving knife, and anti-kickback pawls supplied with the saw should be used for all cutting operations where they can be used.

When performing operations where the guard cannot be used, as in some dadoing operations, alternative safety precautions should be taken. These include push sticks, feather boards, filler pieces, fixtures, jigs and any other appropriate device that can be utilized to keep operators' hands away from the blade.

Upon completion of the operation requiring removal of the guard, the entire guard assembly must be placed back on the machine in its proper working order.

CAUTION Never use a dado head in a tilted position. Never operate the saw without the blade guard, riving knife and anti-kickback pawls for operations where they can be used.

10.0 Safety Devices

10.1 Feather Board

Feather boards, or "combs," can be purchased at most tool stores, or made by the operator to suit particular applications. The feather board (Figure 9-13) should be made of straight grain hardwood approximately 1" thick and 4" to 8" wide depending on the size of the machine. The length is developed in accordance with intended use.

Feather boards can be fastened to the table or rip fence by use of C-clamps. Alternatively, drilled and tapped holes in the table top allow the use of wing nuts and washers as a method of clamping. If this method of fastening is used, provide slots in the feather board for adjustment. (The illustration shows a method of attaching and use of the feather board as a vertical comb. The horizontal application is essentially the same except that the attachment is to the table top.)

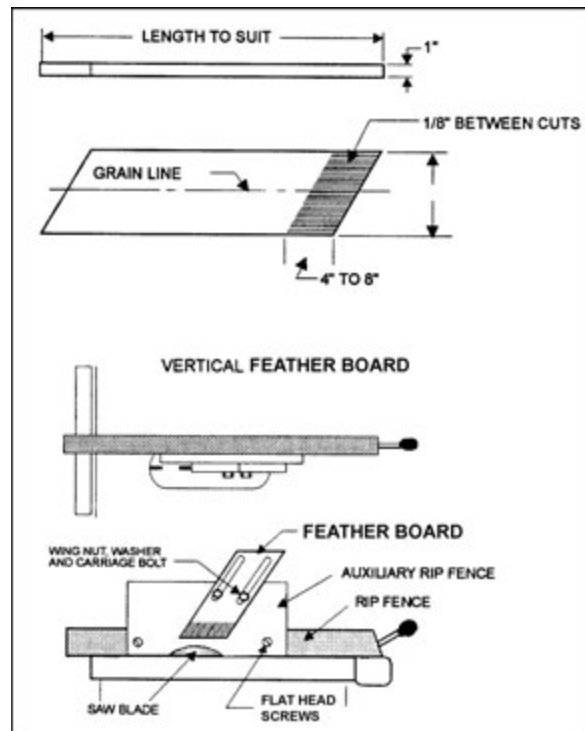

Figure 9-13: feather board

10.2 Push Stick and Push Block

The use of a push block or push stick provides an added level of safety for the operator. A push stick is included with your table saw, but you may wish to make others personalized for different cutting procedures. The templates in Figures 9-15 and 9-16 offer construction details.

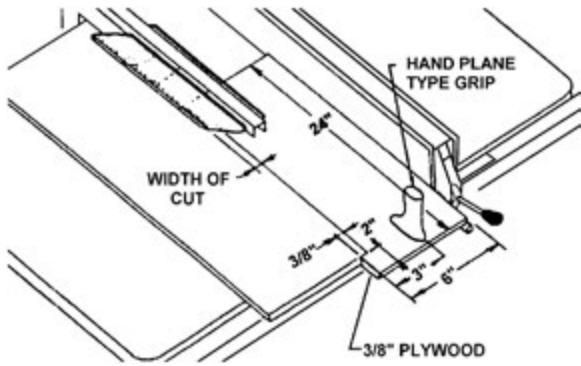

Figure 9-14: push block template

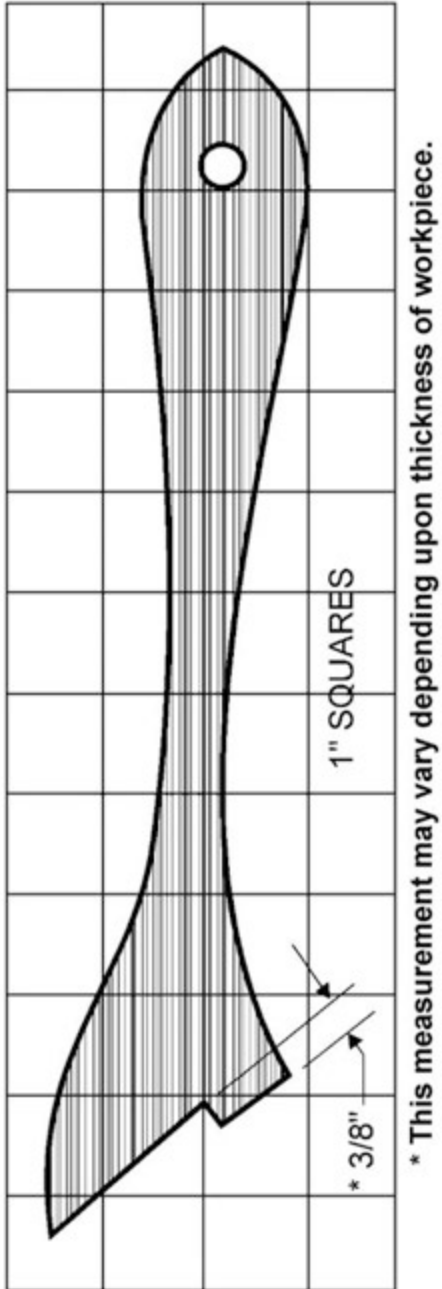

Figure 9-15: push stick template

11.0 Maintenance

⚠WARNING Always disconnect power to machine before performing maintenance. Failure to comply may result in serious personal injury.

⚠CAUTION Model PM2000BT has an industrial-grade low-friction corrosion-resistant coating on the table and table extensions. While the coating is durable, it can be damaged if metal or other hard and/or sharp objects strike, gouge, or scratch the surface. Significant damage to the coating may affect its performance. Use care when cleaning and maintaining the machine.

11.1 General Inspection

Always be aware of the condition of your machine. Routinely check the condition of the following items and repair or replace as necessary:

- Mounting bolts
- Power switch
- Saw blade
- Blade guard assembly

11.2 Cleaning

Note: The following maintenance schedule assumes the saw is being used daily.

DAILY:

- **Model PM2000B:** Wipe down the table surface and T-slots with a rust preventive.
- **Model PM2000BT:** Wipe down the table surface and T-slots.
- Clean pitch and resin from saw blade.

WEEKLY:

- **For Model PM2000B Only:** Table surface must be kept clean and free of rust for best results. To facilitate this, apply a coat of paste wax to the surface. Alternatively, commercial spray protectants are available from local hardware and tool stores. A good protectant should provide rust protection for the surface without staining workpieces.
- Clean the motor fan housing with compressed air.
- Wipe down fence rails with a dry silicon lubricant.

PERIODICALLY:

- Keep cabinet interior and trunnion area clean. Vacuum dust and chips.
- Check for excessive play in tilting and raising mechanism and in saw arbor and adjust as required.
- Check belt for proper tension, and for wear, cracks, frays, etc.

11.3 Lubrication

- Grease the tilting worm gear, raising worm gear, and the trunnion areas with a good grade non-hardening grease.
- Check all adjustments after lubricating, such as handwheel action, blade stops, DRO setting, etc.

11.4 Arbor/Arbor Bearing Removal

The saw arbor is *press fitted* in the saw raising arm housing. If the arbor needs to be removed for bearing replacement, it should be done by a qualified service technician. Contact Powermatic customer service.

11.5 Additional Servicing

Any additional servicing should be performed by authorized service personnel.

12.0 Optional Accessories

These accessory items (purchased separately) can enhance the functionality of your table saw. Contact your dealer to order or call Powermatic at the phone number on the cover. Additional accessories may be available; see our website.



1791788B – Dado Insert



1791791C – High-Profile Thin-Kerf Riving Knife
0.079" (2.0mm) thick



1791786B – Zero-clearance insert



1791792B – Low-Profile Thin-Kerf Riving Knife
0.079" (2.0mm) thick

13.0 Troubleshooting

13.1 Motor and Electrical Problems

Symptom	Probable Cause	Remedy
Saw will not start.	No incoming power.	Check plug connection.
	Safety key removed from switch.	Install safety key.
	Low voltage.	Check power line for proper voltage.
	Open circuit in motor or loose connection.	Inspect all connections on motor for loose or open connections.
	Power cord damaged.	Replace cord.
Saw will not start: fuse blows or breaker trips.	Short circuit in line cord or plug.	Inspect cord or plug for damaged insulation and shorted wires.
	Short circuit in motor or loose connections.	Inspect all connections on motor for loose or shorted terminals or worn insulation.
	Incorrect fuses or circuit breakers in power line.	Install correct fuses or circuit breakers.
Motor starts slowly or fails to reach full speed.	Low voltage.	Request voltage check from power company and correct low voltage condition.
	Power line overloaded.	Correct overload condition. Use dedicated circuit for table saw.
	Undersized wires in supply system.	Increase supply wire size.
	Centrifugal switch not engaging.	Replace centrifugal switch (qualified personnel only).
	Motor malfunction.	Have motor checked by a qualified inspector. Repair or replace.
Motor overheats.	Motor overloaded.	Reduce load on motor.
	Improper cooling of motor; lack of air circulation.	Clean sawdust from fan and duct areas of motor.
Motor stalls, resulting in blown fuses or tripped breaker.	Motor overloaded.	Reduce load on motor.
	Short circuit in motor or loose connections.	Inspect connections on motor for loose or shorted terminals or worn insulation.
	Low voltage.	Correct low voltage conditions.
	Incorrect fuses or circuit breakers in power line.	Install correct fuses or circuit breakers.

Table 4

13.2 Mechanical and Operational Problems

Motor stalls or workpiece binds or burns.	Excessive feed.	Reduce feed.
	Dull or incorrect blade.	Replace blade; use proper type of blade for cut needed.
	Miter slot misaligned.	Realign table to blade.
	Fence misaligned.	Realign fence (see Accu-Fence manual).
	Motor malfunction.	Have motor checked by a qualified inspector. Repair or replace.

Machine slows or stalls when operating.	Applying too much pressure to workpiece.	Feed workpiece more slowly.
	Poly-v drive belt is loose.	Tighten belt.
Loud, repetitive noise coming from machine.	Pulley setscrews or keys are missing or loose.	Inspect keys and setscrews. Replace or tighten if necessary.
	Motor fan is hitting the cover.	Tighten fan or shim cover.
	V-belt is defective.	Replace V-belt.
Excessive vibration.	Tilting or raising lock knobs not tightened.	Tighten lock knobs on handwheels
	Caster system still engaged.	Disengage casters before operating saw.
	Machine not resting evenly on floor.	Make sure floor is level; use shims beneath cabinet if needed.
	Blade out of balance.	Replace blade.
	Pulley loose.	Check motor pulley and spindle pulley. Tighten set screws if needed.
	Belt is worn, cracked, or frayed.	Replace belt.
	Motor malfunction.	Have motor checked by a qualified inspector. Repair or replace.
Blade not square with miter slot, or fence not square to blade.	Blade is warped.	Replace saw blade.
	Table top not parallel to blade.	Adjust table parallel to blade.
	Fence not parallel to blade.	Adjust fence parallel to blade.
Blade does not reach 90 degrees.	90 degree stop is out of adjustment.	Adjust 90 degree stop.
Cuts out-of-square when crosscutting.	Miter gauge out of adjustment.	Re-set stops and pointer on gauge.
	Miter slot misaligned.	Realign table to blade.
Cuts not true at 90 or 45 degrees.	Stop screws not set properly.	Readjust screws.
Tilting or raising handwheel difficult to turn.	Lock knob not released.	Loosen lock knob.
	Worm and trunnion segment caked with sawdust and pitch.	Clean and re-grease worm and segment.
	Worm and trunnion segment out of alignment.	Realign worm with segment (qualified personnel).

Table 5

14.0 Replacement Parts

Replacement parts are listed on the following pages. To order parts or reach our service department, call 1-800-274-6848 Monday through Friday (see our website for business hours, www.powermatic.com). Having the Model Number and Serial Number of your machine available when you call will allow us to serve you quickly and accurately.

Non-proprietary parts, such as fasteners, can be found at local hardware stores, or may be ordered from Powermatic.

Some parts are shown for reference only and may not be available individually.

14.1.1 Table and Cabinet Assembly I – Exploded View

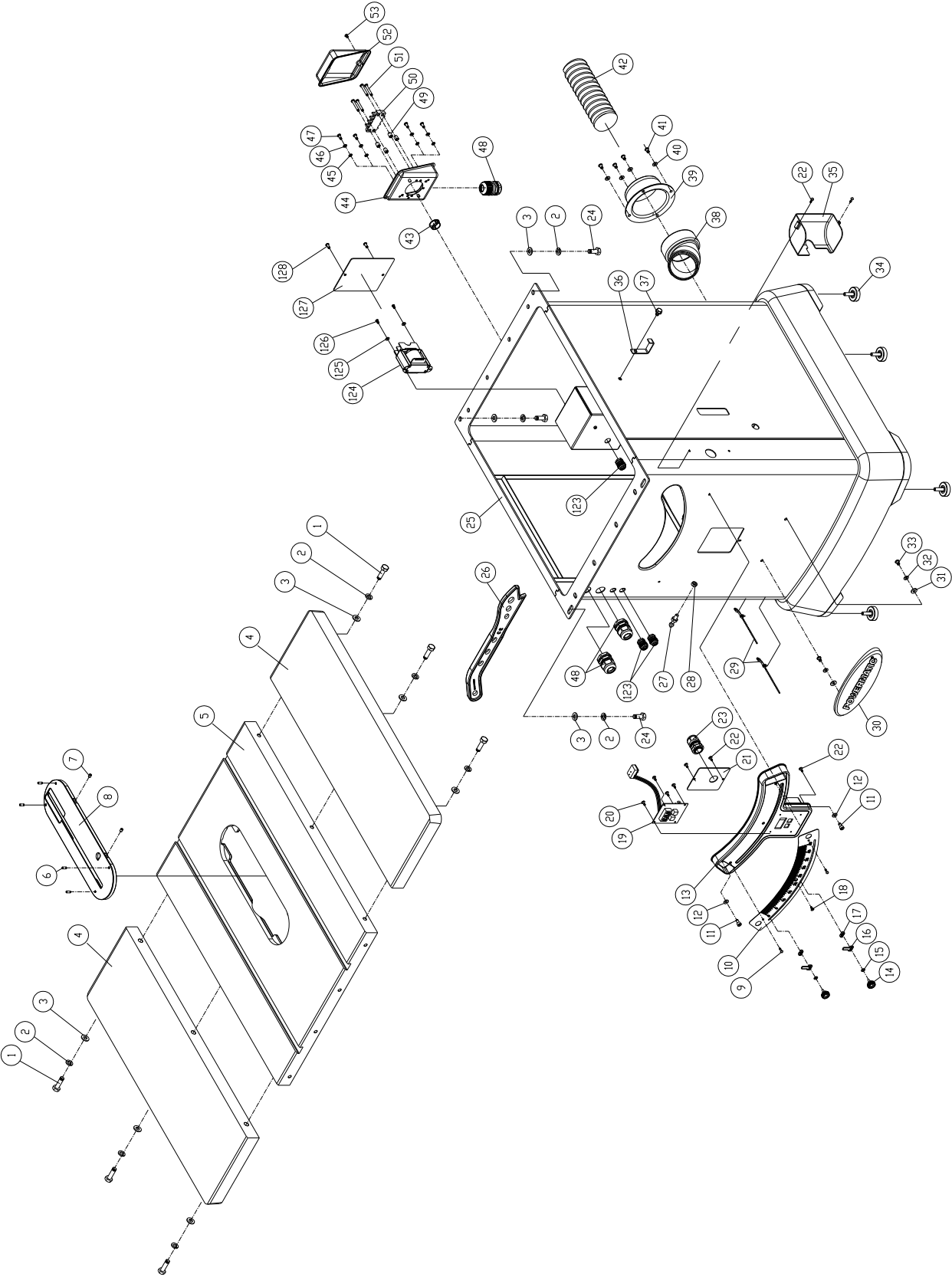

14.1.2 Table and Cabinet Assembly II – Exploded View

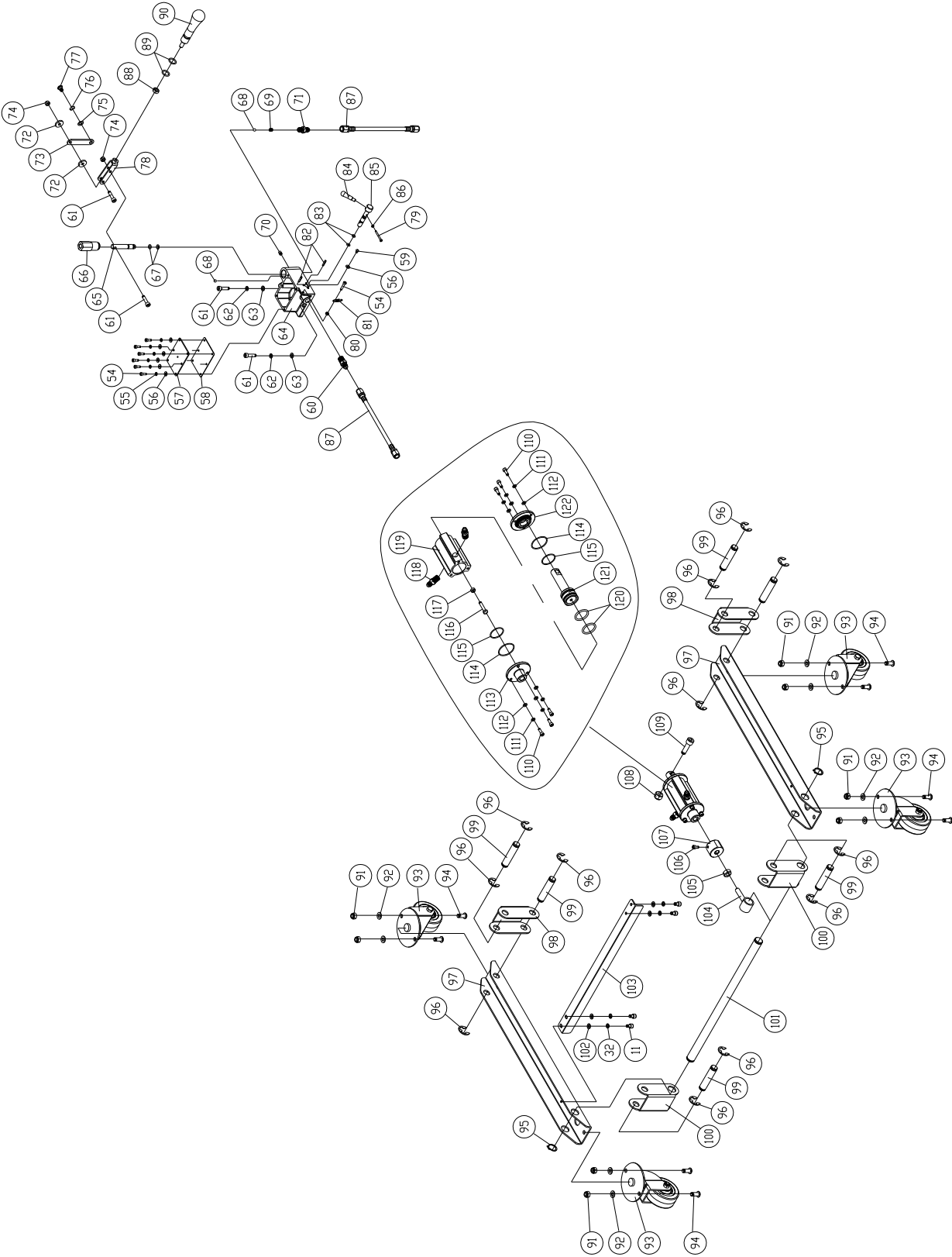

14.1.3 Table and Cabinet Assembly – Parts List

Index No	Part No	Description	Size	Qty
1	TS-149105	Hex Cap Screw	M10-1.5 x 35L	6
2	TS-2361101	Lock Washer	M10	10
3	TS-1550071	Flat Washer	10 x 20 x 2.0T	10
4	PM2000B-104	Extension Table (for PM2000B)		2
	PM2000B-104T	Extension Table (for PM2000BT)		2
5	PM2000B-105	Table (for PM2000B)		1
	PM2000B-105T	Table (for PM2000BT)		1
6	F010395L	Soc Set Screw CPP w/thrdclckr	M5-0.8 x 12L	4
7	PM2000B-107	Plunger		2
8	PM2000B-108	Table Insert		1
	PM2000B-108TIA	Table Insert Assembly (includes #6,7,8)		1
9	PM2000B-109	Phillips Socket HD Tapping Screw	M4-1.41P x 12L	2
10	PM2000B-110	Tilt Angle Scale		1
11	TS-1503031	Socket Head Cap Screw	M6-1.0 x 12L	6
12	TS-1550041	Flat Washer	6.2 x 13 x 1.5T mm	2
13	PM2000B-113	Scale Base w/Label		1
14	PM2000B-114	Angle Reference Knob		2
15	TS-1550031	Flat Washer	5.2 x 10 x 1.0T mm	2
16	PM2000B-116	Specific Angle Reference		2
17	PM2000B-117	Special Nut		2
18	PM2000B-118	Phillips Flat HD Tapping Screw	M4-1.41P x 10L	1
19	PM2000B-119	Sensor Assembly		1
20	PM2000B-120	Phillips Pan HD Tapping Screw	M3 x 1.06P x 10L	4
21	PM2000B-121	DRO Box Cover		1
22	PM2000B-122	Phillips Round HD Tapping Screw	M4 x 1.41P x 10L	5
23	PM2000B-123	Strain Relief	PGA16-14B	1
24	TS-1491031	Hex Cap Screw	M10-1.5 x 25L	4
25	PM2000B-125	Cabinet (for 3HP 1PH and 5HP 1PH)		1
	PM2000B-125A	Cabinet (for 5HP 3PH)		1
26	PM2000B-126	Push Stick		1
27	PM2000B-127	Peg		1
28	TS-2311081	Hex Nut	M8-1.25	1
29	PM2000B-129	Cable Tie		2
30	PM2000B-130	Powermatic Logo		1
31	TS-1550041	Flat Washer	6.7 x 16 x 2.0T mm	2
32	TS-0720071	Lock Washer	1/4"	6
33	PM2000B-133	Phillips Round HD Machine Screw	1/4"-20UNC x 3/8"L	2
34	PM2000B-134	Leveling Foot		4
35	PM2000B-135	Sensor Assembly Cover		1
36	PM2000B-136	Hanger		1
37	PM2000B-137	Hex Cap Screw w/Flat Washer	M8-1.25 x 12L	1
38	PM2000B-138	Dust Chute Adaptor		1
39	PM2000B-139	Dust Port		1
40	TS-1550041	Flat Washer	6.2 x 13 x 1.5T mm	4
41	TS-2246122	Socket Head Button Screw	M6-1.0 x 12L	4
42	PM2000B-142	Dust Hose		1
43	PM2000B-143	Grommet		1
44	PM2000B-144	Terminal Box		1
45	F002097	Lock Washer, Ext Tooth	M5	4
46	TS-1550031	Flat Washer	5.3 x 10 x 2.0T mm	4
47	TS-1533042	Phillips Pan HD Machine Screw	M5-0.8 x 12L	4
48	PM2000B-148	Strain Relief (only for 3HP, 1PH)	MG25AS-14B	1
	PM2000B-148A	Strain Relief (only for 5HP, 1PH & 5HP, 3PH)	MG25A-18B	1
49	PM2000B-149	Spacer		4
50	PM2000B-150	Terminal Plate		1
51	F001221	Phillips Pan HD Machine Screw	M5-0.8 x 35L	4
52	PM2000B-152	Terminal Box Cover		1
53	F000648	Phillips Pan HD Machine Screw	#10-24UNC x 1/4L	1
54	TS-1501041	Socket Head Cap Screw	M4-0.7 x 12L	7
55	TS-2361041	Lock Washer	M4	6

Index No	Part No	Description	Size	Qty
56	TS-1550021	Flat Washer	4.3 x 10 x 1.0T mm	7
57	PM2000B-157	Oil Tank Cover		1
58	PM2000B-158	Gasket		1
59	F009923	Socket Head Button Screw	M4-0.7 x 6L	1
60	PM2000B-160	Oil Hose Fitting	PT1/4" x PH1/4"	1
61	TS-1503061	Socket Head Cap Screw	M6-1.0 x 25L	4
62	TS-1551041	Lock Washer	M6	2
63	TS-1550041	Flat Washer	6.4 x 11.5 x 1.6T mm	2
64	PM2000B-164	Oil Tank		1
65	PM2000B-165	Pump Shaft		1
66	PM2000B-166	Pump Shaft Sleeve		1
67	JMS10SCMS-43	O-Ring	P7	2
68	SB-6MM	Steel Ball	6 Dia.	2
69	PM2000B-169	Compression Spring		1
70	TS-2276081	Socket Set Screw	M6-1.0 x 8L	1
71	PM2000B-171	Oil Hose Fitting	TH1/4" x TH1/4"	1
72	TS-1550041	Flat Washer	6.2 x 20 x 3.0T mm	2
73	PM2000B-173	Linkage		1
74	TS-1541021	Nylon Lock Hex Nut	M6-1.0	2
75	TS-1541031	Flat Washer	8.5 x 16 x 1.0T mm	1
76	JMS10SCMS-37	Wave Washer	WW-8	1
77	PM2000B-177	Shoulder Screw		1
78	PM2000B-178	Linkage		1
79	F005344	Socket Head Cap Screw	M3-0.5 x 20L	1
80	TS-1540021	Hex Nut	M4-0.7	1
81	PM2000B-181	Tension Spring		1
82	F012097	Roll Pin	3 x 16mm	2
83	CK350-722	O-Ring	P5	2
84	PM2000B-184	Knob		1
85	PM2000B-185	Oil Release Shaft		1
86	TS-1540011	Hex Nut	M3-0.5	1
87	PM2000B-187	Oil Hose Assembly		2
88	TS-1540061	Hex Nut	M8-1.25	1
89	5784696	O-Ring	P15	2
90	PM2000B-190	Pump Handle		1
91	TS-1541031	Nylon Lock Hex Nut	M8-1.25	8
92	TS-1550061	Flat Washer	8 x 16 x 1.6T mm	8
93	PM2000B-193	Caster		4
94	TS-2248202	Socket Head Button Screw	M8-1.25 x 20L	8
95	F006047	C-Retaining Ring, Ext	STW-20	2
96	F006088	E-Retaining Ring	ETW-15	12
97	PM2000B-197	Linkage		2
98	PM2000B-198	Drive Caster Bracket		2
99	PM2000B-199	Pivot		6
100	PM2000B-1100	Driven Caster Bracket		2
101	PM2000B-1101	Connection Rod		1
102	TS-1550041	Flat Washer	6.3 x 13 x 1.0T mm	4
103	PM2000B-1103	Brace		1
104	PM2000B-1104	Connecting Collar		1
105	TS-2311121	Hex Nut	M12-1.75	1
106	F005363L	Socket Hd Cap Screw w/thrdlckr	M5-0.8 x 10L	1
107	PM2000B-1107	Special Nut		1
108	TS-2342101	Nylon Lock Hex Nut	M10-1.5	1
109	TS-1505061	Socket Head Cap Screw	M10-1.5 x 40L	1
	PM2000B-HCA	Hydraulic Cylinder Assembly (includes #110 thru #122)		1
110	HVBS710SG-314	Socket Head Cap Screw	M5-0.8 x 15L	6
111	TS-1551031	Lock Washer	M5	6
112	TS-1550031	Flat Washer	5.2 x 10 x 1.0T mm	6
113	PM2000B-1113	Non-drive End Bell		1
114	PM2000B-1114	O-Ring	AS029	2
115	PM2000B-1115	O-Ring	AS026	2
116	TS-1482061	Hex Cap Screw	M6-1.0 x 30L	1

Index No	Part No	Description	Size	Qty
117	TS-2311061	Hex Nut	M6-1.0	1
118	PM2000B-1118	Oil Hose Fitting	PT1/4" x PH1/4"	2
119	PM2000B-1119	Hydraulic Cylinder		1
120	PM2000B-1120	O-Ring	P29	2
121	PM2000B-1121	Piston		1
122	PM2000B-1122	Drive End Bell		1
123	PM2000B-1123	Strain Relief	MGB16-10B	3
124	PM2000B-1124	Transformer Assembly w/ Fuse		1
125	TS-1550021	Flat Washer	4.3 x 10 x 1.0T mm	2
126	TS-2284082	Phillips Pan HD Machine Screw	M4-0.7 x 8L	2
127	PM2000B-1127	Transformer Box Cover		1
128	F009884	Socket Head Button Screw	M5-0.8 x 8L	2
129	PM2000B-1129	Fuse	2A x 250V	2
	LM000304	Warning Label (not shown)		1
	LM000305	ID Label, PM2000B, 3HP 1PH (not shown)		1
	LM000312	ID Label, PM2000B, 5HP 1PH (not shown)		1
	LM000313	ID Label, PM2000B, 5HP 3PH (not shown)		1
	LM000305T	ID Label, PM2000BT, 3HP 1PH (not shown)		1
	LM000312T	ID Label, PM2000BT, 5HP 1PH (not shown)		1
	LM000313T	ID Label, PM2000BT, 5HP 3PH (not shown)		1
	CL-HV	Caution Label - High Voltage (not shown)		2
	PM2000B-1133	Black Stripe (not shown)	1"W	per ft.
	LM000307	Label - Caster Lift (not shown)		1
	LM000308	Label - Caster Lower (not shown)		1

14.2.1 Motor and Trunnion Assembly I – Exploded View

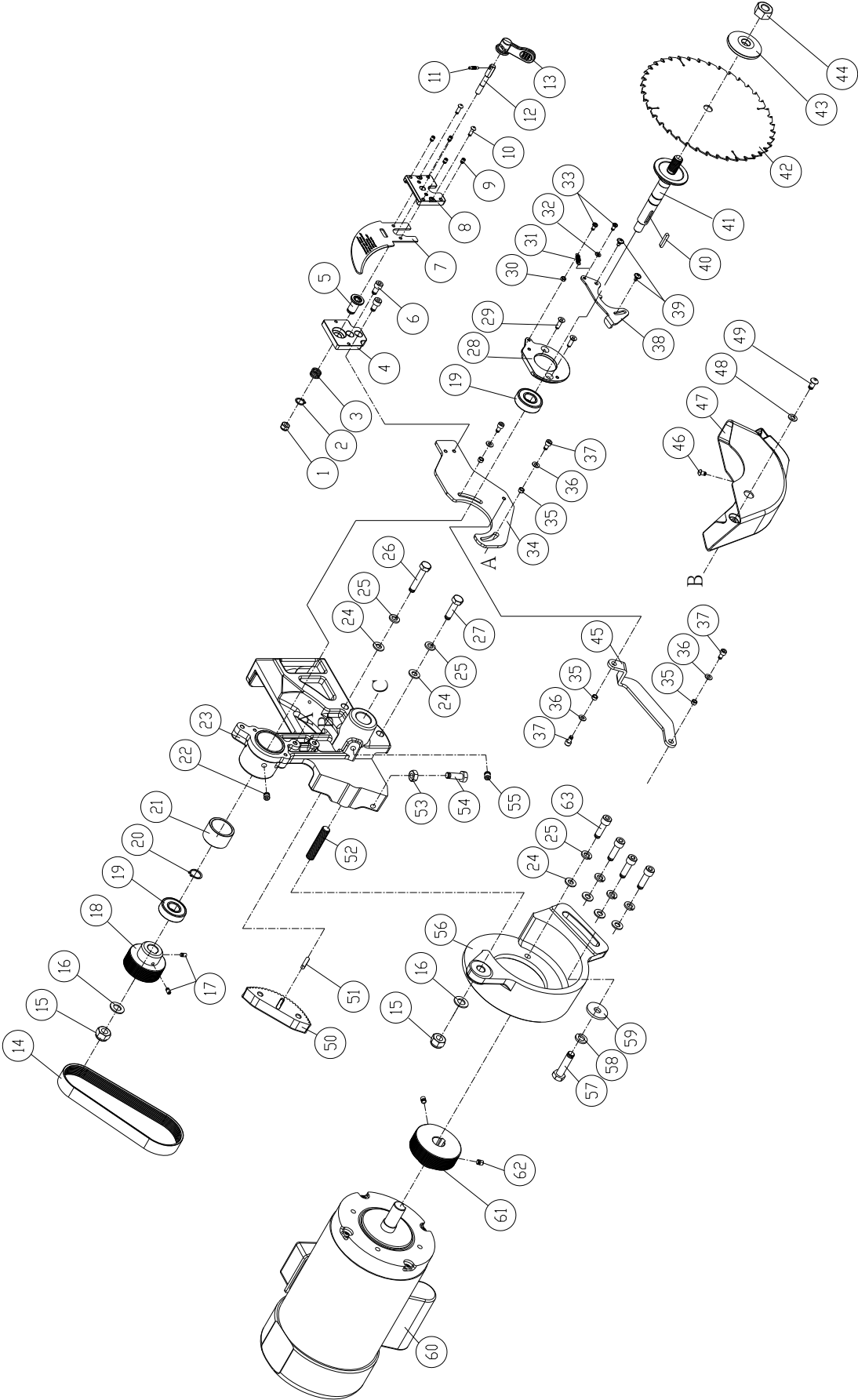

14.2.2 Motor and Trunnion Assembly II – Exploded View

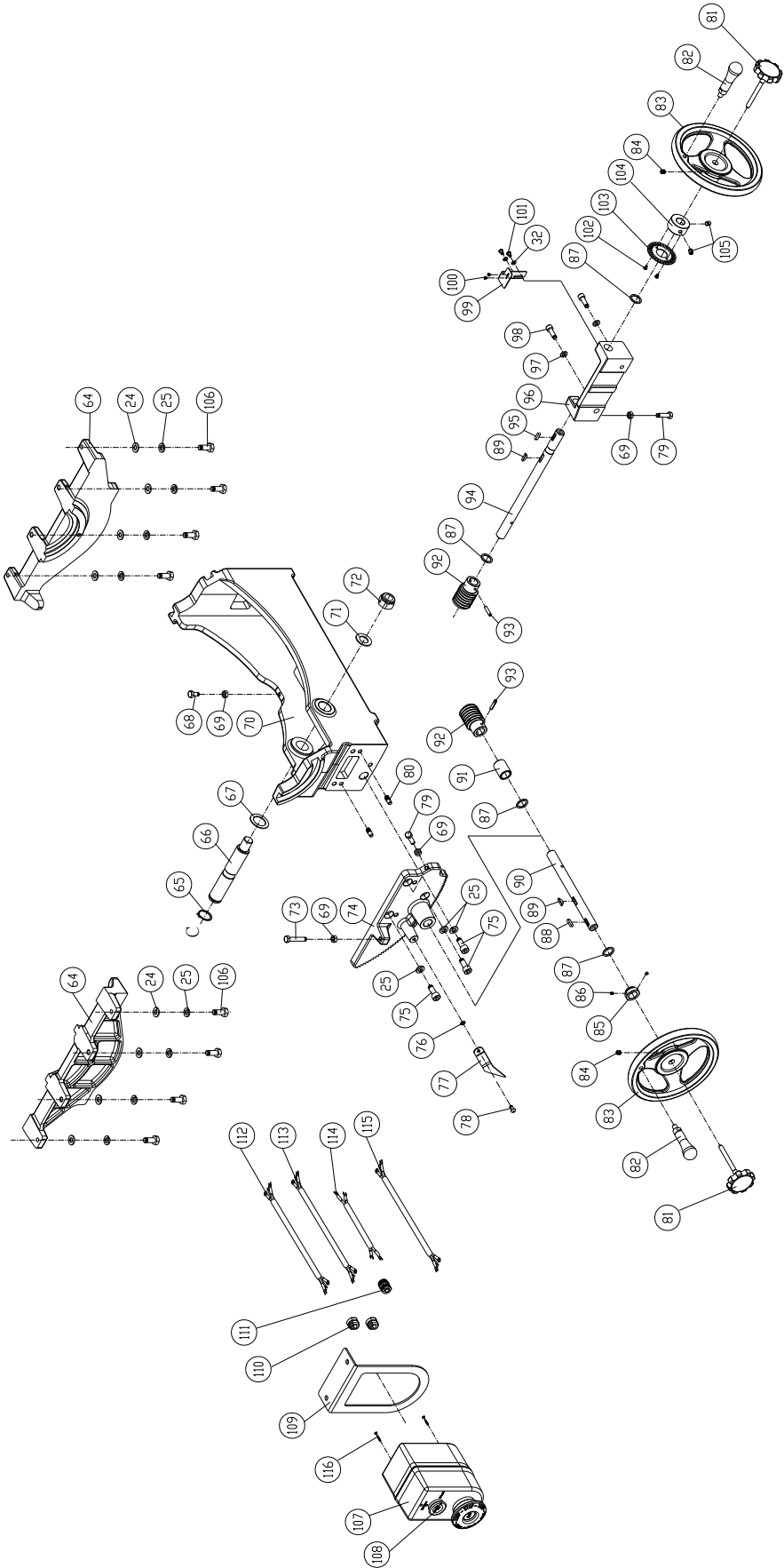

14.2.3 Motor and Trunnion Assembly – Parts List

Index No	Part No	Description	Size	Qty
1	TS-1541031	Nylon Lock Hex Nut	M8-1.25	1
2	F006042	C-Retaining Ring, Ext	STW-14	1
3	PM2000B-203	Compression Spring		1
4	PM2000B-204	Riving Knife Fixed Base		1
5	PM2000B-205	Clamping Block		1
6	TS-1504031	Socket Head Cap Screw	M8-1.25 x 16L	2
7	PM2000B-207	Low Profile Riving Knife	0.1"(2.5mm) thk	1
8	PM2000B-208	Riving Knife Clamp Plate		1
9	TS-2276081	Socket Set Screw	M6-1.0 x 8L	4
10	TS-2245162	Socket Head Button Screw	M5-0.8 x 16L	2
11	PM2000B-211	Solid Pin		1
12	PM2000B-212	Shaft		1
13	PM2000B-213	Lever		1
14	VB-220J10	Poly-V Belt	220J-10	1
15	TS-2342141	Nylon Lock Hex Nut	M14-2.0	2
16	TS-155009	Flat Washer	14.2 x 26 x 2T mm	2
17	F010401L	Soc Set Scrw CPP w/thrdlckr	M6-1.0 x 8L	2
18	PM2000B-218	Arbor Pulley		1
19	BB-6204VV	Ball Bearing	6204VV	2
20	F006047	C-Retaining Ring, Ext	STW-20	1
21	PM2000B-221	Bushing		1
22	F010414L	Socket Set Screw CPP w/thrdlckr	M10-1.5 x 10L	1
23	PM2000B-223	Bearing Arm		1
24	TS-1550071	Flat Washer	10 x 20 x 2.0T mm	14
25	TS-2361101	Lock Washer	M10	17
26	JTS315PST-08	Hex Cap Screw	M10-1.5 x 55L	1
27	TS-1491061	Hex Cap Screw	M10-1.5 x 40L	1
28	PM2000B-228	Fixed Plate		1
29	TS-2286201	Phillips Flat HD Machine Screw	M6-1.0 x 20L	2
30	TS-1540031	Hex Nut	M5-0.8	1
31	PM2000B-231	Tension Spring		1
32	TS-1550031	Flat Washer	5.3 x 10 x 2.0T mm	3
33	F001208L	Pan HD Mach Scrw w/thrdlckr	M5-0.8 x 8L	2
34	PM2000B-234	Riving Knife Extension Plate		1
35	PM2000B-235	Bushing		4
36	TS-1550041	Flat Washer	6.3 x 13 x 1.0T mm	4
37	F005267L	Soc Hd Cap Screw w/thrdlckr	M6-1.0 x 12L	4
38	PM2000B-238	Spindle Lock		1
39	PM2000B-239	Shoulder Screw		2
40	6291479	Flat Key, Dbl Rd Hd	5 x 5 x 30mm	1
41	PM2000B-241	Arbor		1
42	PM2000B-242	Saw Blade	10" 40T 5/8A ATB	1
43	PM2000B-243	Flange		1
44	PM2000B-244	Nut		1
45	PM2000B-245	Link		1
46	F009893L	Soc Hd Button Screw w/thrdlckr	M6-1.0 x 10L	1
47	PM2000B-247	Dust Chute		1
48	TS-1550061	Flat Washer	8.5 x 16 x 1.5T mm	1
49	TS-2248162	Socket Head Button Screw	M8-1.25 x 16L	1
50	PM2000B-250	Elevation Gear Block		1
51	DT45-110	Flat Key, Dbl Rd Hd	6 x 6 x 30 mm	1
52	PM2000B-252	Socket Set Screw	M14-2.0 x 70L	1
53	TS-2311101	Hex Nut	M10-1.5	1
54	TS-1491041	Hex Cap Screw	M10-1.5 x 30L	1
55	F010418L	Soc Set Screw CPP w/thrdlckr	M10-1.5 x 25L	1
56	PM2000B-256	Motor Rotation Bracket		1
57	TS-1492051	Hex Cap Screw	M12-1.75P x 50L	1
58	TS-2361121	Lock Washer	M12	1
59	PM2000B-259	Flat Washer	13 x 28 x 3.0T mm	1

Index No	Part No	Description	Size	Qty
60	PM2000B-260	Motor	3HP 230V 60Hz 1PH	1
	PM2000B-260SC	Starting Capacitor	400MFD 125VAC	1
	PM2000B-260RC	Running Capacitor	40µF 350VAC	1
	PM2000B-260CC	Capacitor Cover		2
	PM2000B-260F	Fan		1
	PM2000B-260FC	Fan Cover		1
	PM2000B-260CS	Centrifugal Switch		1
	LM000316	Motor Label, PM2000B (3HP 1PH)		1
	PM2000B-260A	Motor	5HP 230V 60Hz 1PH	1
	PM2000B-260ASC	Starting Capacitor	400MFD 250VAC	1
	PM2000B-260ARC	Running Capacitor	30µF 500VAC	1
	PM2000B-260CC	Capacitor Cover		1
	PM2000B-260ARCC	Running Capacitor Cover		1
	PM2000B-260AF	Fan		1
	PM2000B-260AFC	Fan Cover		1
	PM2000B-260CS	Centrifugal Switch		1
	LM000317	Motor Label, PM2000B (5HP 1PH)		1
	PM2000B-260B	Motor	5HP 230/460V 60Hz 3PH	1
	PM2000B-260F	Fan		1
	PM2000B-260FC	Fan Cover		1
	LM000318	Motor Label, PM2000B (5HP 3PH)		1
61	PM2000B-261	Motor Pulley		1
62	PM2000B-262	Soc Set Screw CPP w/thrdlckr	M8-1.25 x 20L	2
63	TS-1505051	Socket Head Cap Screw	M10-1.5 x 35L	4
64	PM2000B-264	Trunnion		2
65	F006051	C-Retaining Ring, Ext	STW-28	1
66	PM2000B-266	Shaft		1
67	PM2000B-267	Nylon Washer		1
68	TS-1490021	Hex Cap Screw	M8-1.25 x 16L	1
69	TS-2311081	Hex Nut	M8-1.25	4
70	PM2000B-270	Center Trunnion		1
71	PM2000B-271	Flat Washer	21 x 38 x 3T mm	1
72	PM2000B-272	Nylon Lock Hex Nut	M20-1.5P	1
73	TS-1490081	Hex Cap Screw	M8-1.25 x 45L	1
74	PM2000B-274	Tilt Gear Block		1
75	TS-1505041	Socket Head Cap Screw	M10-1.5 x 30L	3
76	JWBS10OS-107	Lock Washer Ext Tooth	M6	1
77	PM2000B-277	Angle Pointer		1
78	TS-2246122	Socket Head Button Screw	M6-1.0 x 12L	1
79	TS-1490051	Hex Cap Screw	M8-1.25 x 30L	2
80	PM2000B-280	Roll Pin		2
81	PM2000B-281	Locking Knob		2
82	PM2000B-282	Handle		2
83	PM2000B-283	Handwheel		2
84	F010052L	Soc Set Screw CPP w/thrdlckr	5/16"-18UNC x 5/16"	2
85	PM2000B-285	Collar		1
86	F010449L	Soct Set Screw CPP w/thrdlckr	M5-0.8 x 5L	2
87	PM2000B-287	Nylon Washer	19.1 x 25.4 x 1.6T mm	4
88	5509207	Flat Key, Dbl Rd Hd	5 x 5 x 20mm	1
89	PM2000B-289	Woodruff Key		2
90	PM2000B-290	Elevation Handwheel Shaft		1
91	PM2000B-291	Bushing		1
92	PM2000B-292	Worm Shaft		2
93	F012076	Roll Pin	5 x 30mm	2
94	PM2000B-294	Tilt Handwheel Shaft		1
95	5783961	Flat Key, Dbl Rd Hd	5 x 5 x 18mm	1
96	PM2000B-296	Tilt Worm Shaft Base		1
97	TS-2361081	Lock Washer	M8	2
98	TS-1504061	Socket Head Cap Screw	M8-1.25 x 30L	2
99	PM2000B-299	Bracket		1
100	PM2000B-2100	Phillips Pan HD Tapping Screw	M3-1.06 x 6L	2

Index No	Part No	Description	Size	Qty
101	F001208	Phillips Pan HD Machine Screw	M5-0.8 x 8L	2
102	TS-2171012	Phillips Pan HD Machine Screw	M4-0.7 x 6L	2
103	PM2000B-2103	Induction Disc		1
104	PM2000B-2104	Collar		1
105	F010408L	Soc Set Screw CPP w/thrdlckr	M8-1.25 x 10L	2
106	TS-1491031	Hex Cap Screw	M10-1.5 x 25L	8
107	PM2000B-2107	Magnetic Switch Assembly	3HP 230V 60Hz 1PH	1
	PM2000B-2107OR	Overload Relay	NTH14	1
	PM2000B-2107A	Magnetic Switch Assembly	5HP 230V 60Hz 1PH	1
	PM2000B-2107AOR	Overload Relay	NTH21	1
	PM2000B-2107B	Magnetic Switch Assembly	5HP 230/460V 60Hz 3PH	1
	PM2000B-2107BOR	Overload Relay (230V)	NTH15	1
	PM2000B-2107BORA	Overload Relay (460V)	NTH8	1
108	PM2000B-2108	Safety Key		1
109	PM2000B-2109	Switch Plate		1
110	PM2000B-2110	Strain Relief (3HP, 1PH)	SR-7R3	2
	PM2000B-2110A	Strain Relief (5HP, 1PH & 5HP, 3PH)	SR-8R3	2
111	PM2000B-2111	Strain Relief (3HP, 1PH & 5HP, 1PH)	MGB16-10B	1
	PM2000B-2111A	Strain Relief (5HP, 3PH)	MGB16-10B	2
112	PM2000B-2112	Motor Cable	SJT 12AWG x 3C x 1900mm	1
	PM2000B-2112A	Motor Cable	SJT 10AWG x 3C x 1900mm	1
	PM2000B-2112B	Motor Cable	ST 12AWG x 4C x 1900mm	1
113	PM2000B-2113	Power Cable	SJT 12AWG x 3C x 2000mm	1
	PM2000B-2113A	Power Cable	SJT 10AWG x 3C x 2000mm	1
	PM2000B-2113B	Power Cable	ST 12AWG x 4C x 2000mm	1
114	PM2000B-2114	DRO Cable	SJT18AWG x 2C x 1400mm	1
115	PM2000B-2115	Transformer Cable	SJT 18AWG x 3C x 2100mm	1
116	PM2000B-2116	Phillips Pan HD Tapping Screw	M5-2.12 x 25	2
117	PM2000B-2117	Arbor Wrench (not shown)		1

14.3.1 Blade Guard Assembly – Exploded View

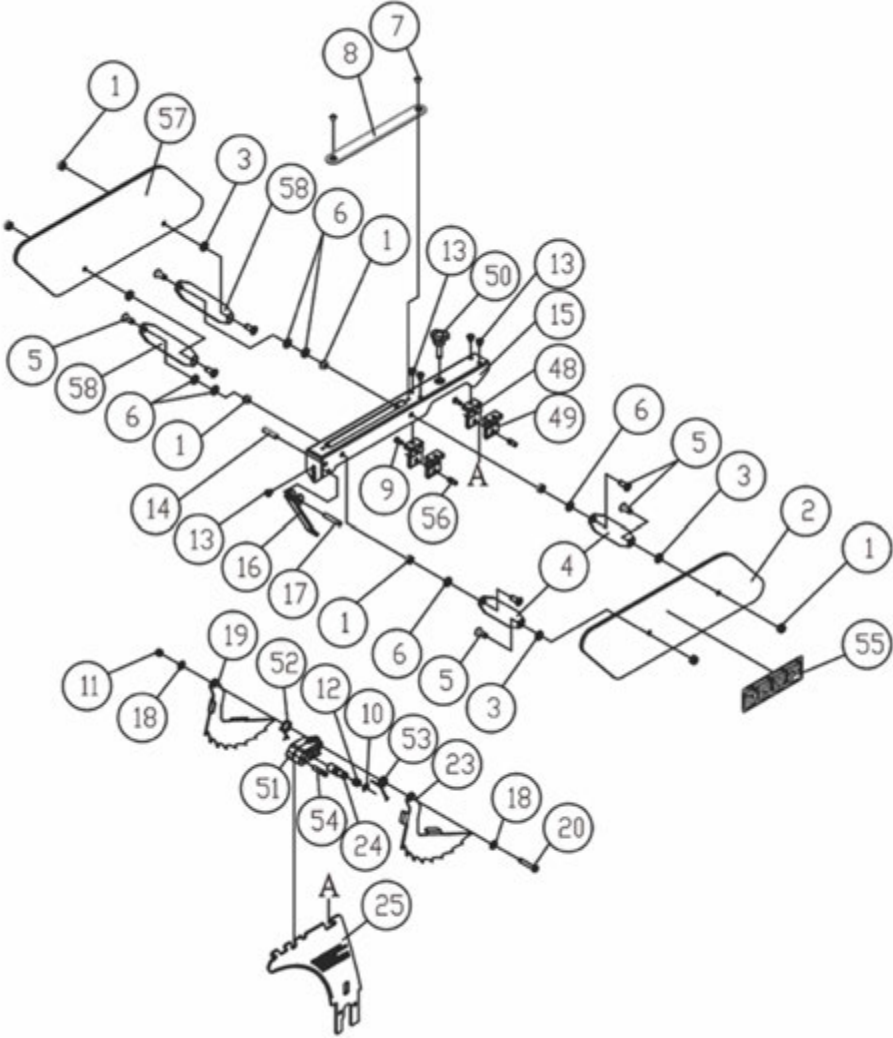

14.3.2 Blade Guard Assembly – Parts List

Index No	Part No	Description	Size	Qty
	PM2000B-BGAB	Blade Guard Assembly (includes #1-9, 13-17, 48-50, 55, 56) *		1
1	TS-1541021	Nylon Lock Hex Nut	M6-1.0	8
2	PM2000B-302B	Left Blade Guard Side Shield		2
3	PM2000B-303	Flat Washer Thin	6.7 x 16 x 1.0T	4
4	PM2000B-304	Left Linkage		4
5	TS-1534051	Phillips Flat HD Machine Screw	M6-1.0 x 16L	8
6	TS-1550041	Flat Washer	6.7 x 16 x 2.0T	6
7	TS-2284081	Phillips Flat HD Machine Screw	M4-0.7 x 8L	2
8	PM2000B-308	Top Sight Shield		1
9	TS-1532032	Phillips Pan HD Machine Screw	M4-0.7 x 10L	2
10	F006090	E-Retaining Ring	ETW-7	2
11	TS-1541011	Nylon Lock Hex Nut	M5-0.8	4
12	PM2000B-312B	Compression Spring		1
13	6286494	Phillips Pan HD Machine Screw	M5-0.8 x 6L	5
14	1014960	Roll Pin	5 x 40mm	1
15	PM2000B-315C	Blade Guard Body		1
16	PM2000B-316B	Front Shield		1
17	3P12314	Roll Pin	5 x 32mm	1
	PM2000B-APAB	Anti-Kickback Pawl Assembly (includes #10-12,18-20, 23-24, 51-54)		1
18	TS-1550031	Flat Washer	5.3 x 12 x 1.0T	2
19	PM2000B-319C	Left Anti-Kickback Pawl		1
20	PM2000B-320	Phillips Pan HD Machine Screw	M5-0.8 x 30L	1
23	PM2000B-323C	Right Anti-Kickback Pawl		1
24	PM2000B-324B	Anti-Kickback Pawl Lock Pin		1
25	PM2000B-325B	Riving Knife	2.3mm thk	1
48	PM2000B-348	Left Lock Pin Holder		2
49	PM2000B-349	Right Lock Pin Holder		2
50	PM2000B-350	Locking Knob		1
51	PM2000B-351	Pawl Holder		1
52	PM2000B-352	Right Torsion Spring		1
53	PM2000B-353	Left Torsion Spring		1
54	PM2000B-354	Solid Pin		1
55	LM000309B	Warning Label - Blade Guard		1
56	PM2000B-356B	Riving Knife Lock Pin		1
57	PM2000B-357	Right Blade Guard Side Shield		1
58	PM2000B-358	Right Linkage		2

* for models with serial no. 22022000B2889 and higher.

14.4.1 PM2000B Miter Gauge Assembly – Exploded View

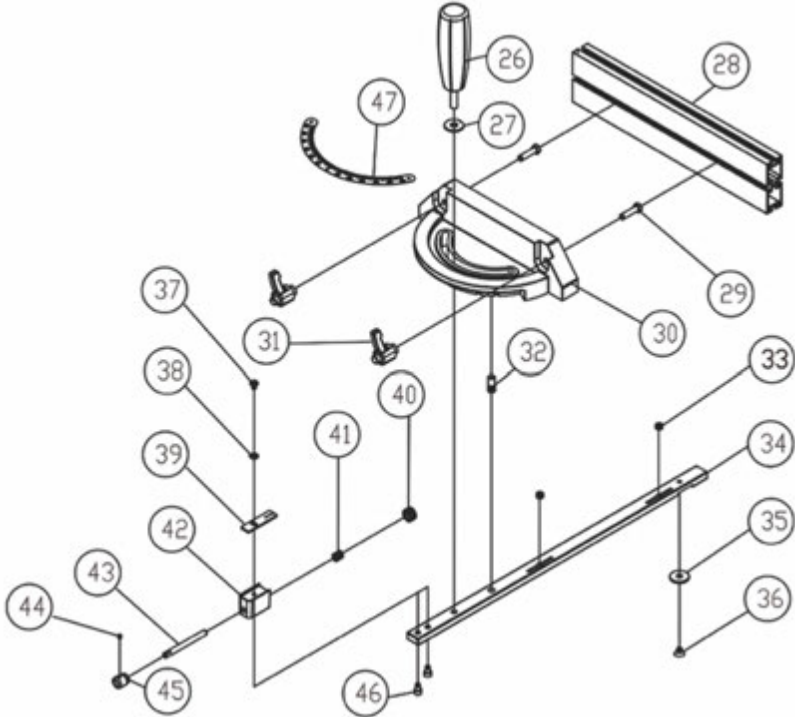

14.4.2 PM2000B Miter Gauge Assembly – Parts List

Index No	Part No	Description	Size	Qty
.....	PM2000B-MGA.....	Miter Gauge Assembly (includes #26 thru 47)	1
26	PM2000B-326	Knob	1
27	TS-1550061	Flat Washer	8.5 x 23 x 2.0T	1
28	PM2000B-328	Fence	1
29	TS-0050051	Hex Cap Screw	1/4"-20UNC x 1"	2
30	PM2000B-330	Miter Gauge Body	1
31	PM2000B-331	Universal Handle	2
32	PM2000B-332	Pin	1
33	F010450.....	Socket Set Screw CPP	M8-1.25 x 5L.....	2
34	PM2000B-334	Miter Bar	1
35	PM2000B-335	Guide Washer	1
36	F001220.....	Phillips Flat HD Machine Screw	M6-1.0 x 8L.....	1
37	TS-0810012	Round HD Machine Screw	#10-24 x 1/4"L	1
38	TS-1550031	Flat Washer	5.2 x 10 x 1.0T	1
39	PM2000B-339	Pointer	1
40	PM2000B-340	Pinion	1
41	PM2000B-341	Compression Spring.....	1
42	PM2000B-342	Pinion Shaft Hub	1
43	PM2000B-343	Shaft	1
44	TS-1521011	Socket Set Screw	M4-0.7P x 4L	1
45	PM2000B-345	Knob	1
46	TS-1502011	Socket Head Cap Screw	M5-0.8P x 8L	2
47	PM2000B-347	Scale	1

14.5.1 PM2000BT Miter Gauge Assembly – Exploded View

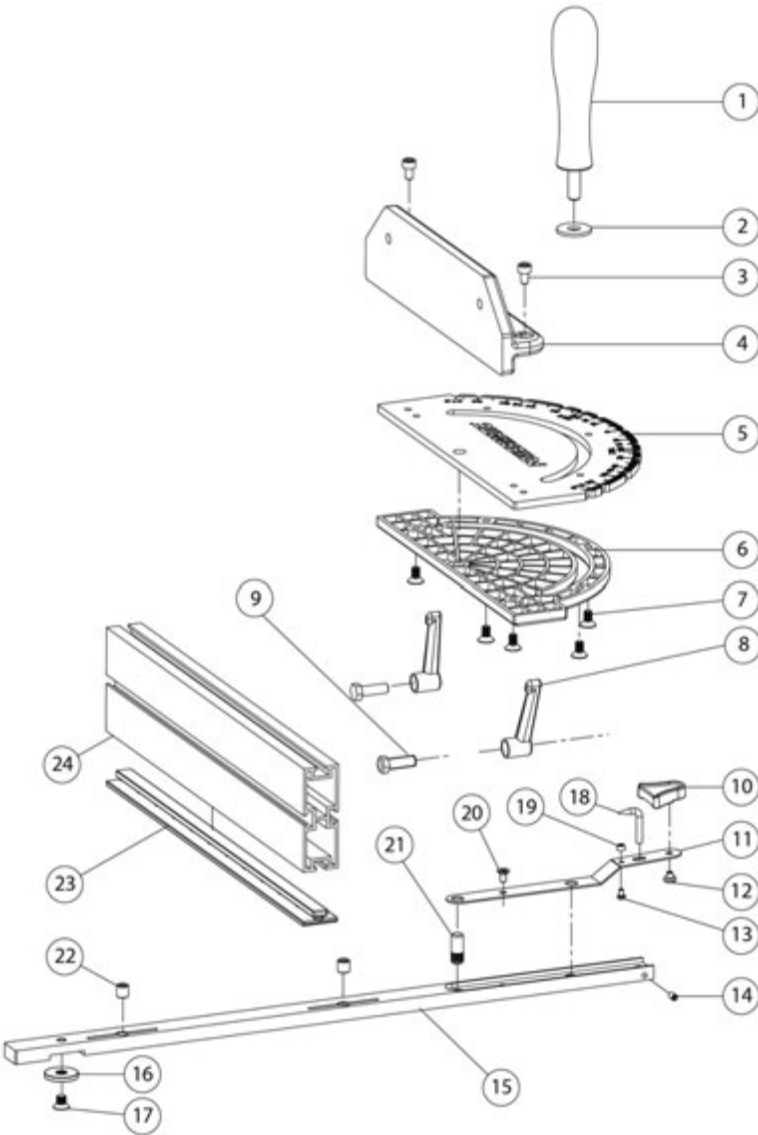

14.5.2 PM2000BT Miter Gauge Assembly – Parts List

Index No	Part No	Description	Size	Qty
	PM2000B-MGAT	Miter Gauge Assembly (includes #1 thru 24)		1
1	PM1500-109T-01	Gauge Plate Locking Handle		1
2	TS-1550061	Flat Washer	8.5 x 23 x 2T	1
3	TS-1502011	Socket Head Cap Screw	M5 x 0.8P x 8L	2
4	PM2000B-MGAT-04	Fence Rest		1
5	PM2000B-MGAT-05	Gauge Plate		1
6	PM2000B-MGAT-06	Non-Marring Bottom Plate		1
7	TS-1533042	Phillips Flat Head Screw	M5 x 0.8P x 12L	5
8	PM2000B-MGAT-08	Fence Locking Handle		2
9	TS-0050031	Hex Cap Screw	1/4-20 x 3/4"	2
10	PM1500-109T-08	Thumb Tab		1
11	PM2000B-MGAT-11	Bracket		1
12	PM1500-109T-09	Phillips Pan Head Screw	M4 x 0.7P x 5L	1
13	PM1500-109T-10	Phillips Pan Head Screw	M3 x 0.5P x 4L	1
14	PM1500-109T-11	Socket Heat Set Screw	M4 x 0.7P x 6L	1
15	PM2000B-MGAT-15	Guide Bar		1
16	PM1500-109T-13	Guide Disc		1
17	PM1500-109T-14	Phillips Flat Head Screw	M6 x 1.0P x 8L	1
18	PM1500-109T-15	Pointer		1
19	PM1500-109T-16	Positive Tab		1
20	TS-2284081	Phillips Flat Head Screw	M4 x 0.7P x 8L	1
21	PM1500-109T-19	Pivot Shaft		1
22	PM1500-109T-20	Socket Head Set Screw	M8 x 1.25P x 6L	2
23	PM2000B-MGAT-23	Non-Marring Bottom Plate for Fence		1
24	PM2000B-MGAT-24	Fence		1

14.6.1 Motor Cover Assembly – Exploded View

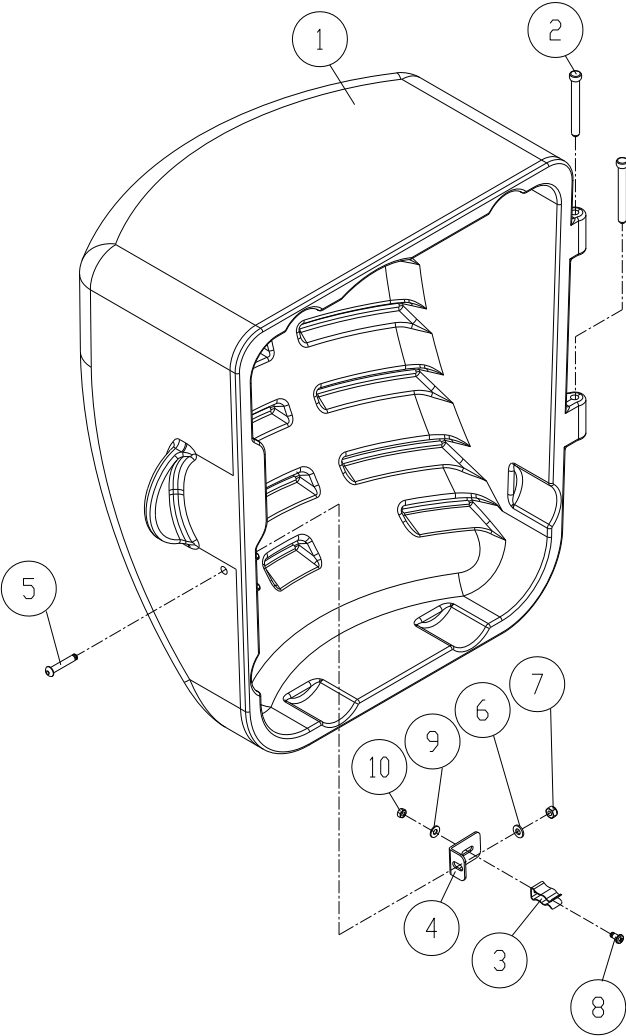

14.6.2 Motor Cover Assembly – Parts List

Index No	Part No	Description	Size	Qty
.....	6827044B.....	Motor Cover Assembly (includes #1 thru 10)		1
1	PM2000B-401	Motor Cover.....		1
2.....	PM2000B-402.....	Hinge Pin.....		2
3.....	PM2000B-403.....	Spring Clamp.....		1
4.....	PM2000B-404.....	Clamp Holder		1
5.....	TS-2246302.....	Socket Head Button Screw	M6-1.0 x 30L.....	1
6.....	TS-1550041.....	Flat Washer.....	6.2 x 13 x 1.5T mm.....	1
7.....	TS-1541021.....	Nylon Lock Hex Nut.....	M6-1.0	1
8.....	TS-1533032.....	Phillips Pan HD Machine Screw.....	M5-0.8 x 10L.....	1
9.....	TS-1550031.....	Flat Washer.....	5.3 x 12 x 1.0T mm.....	1
10.....	TS-1540031.....	Hex Nut	M5-0.8	1

15.0 Electrical Connections

15.1 Wiring diagram – 3HP, 230V, 1PH

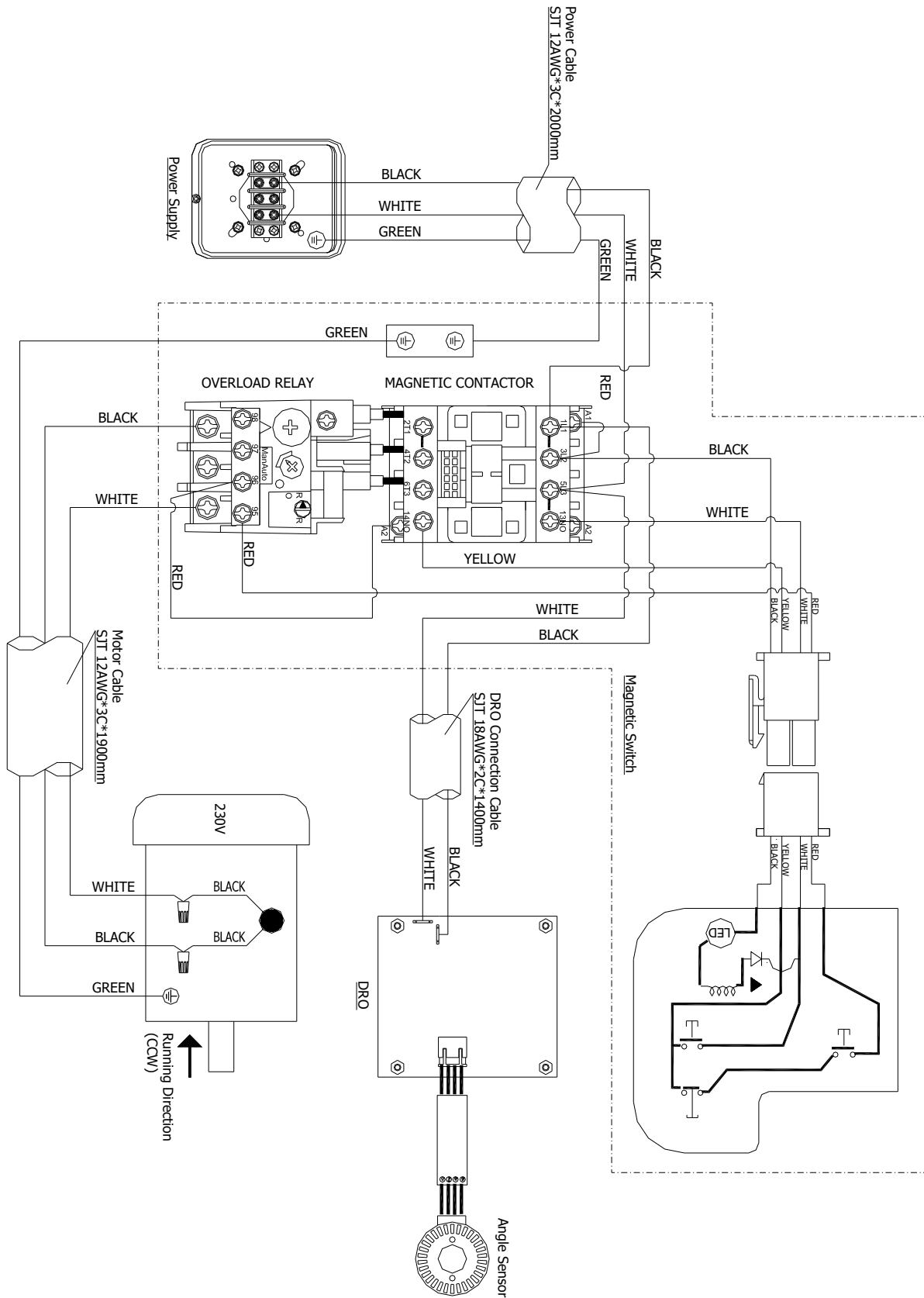

15.2 Wiring diagram – 5HP, 230V, 1PH

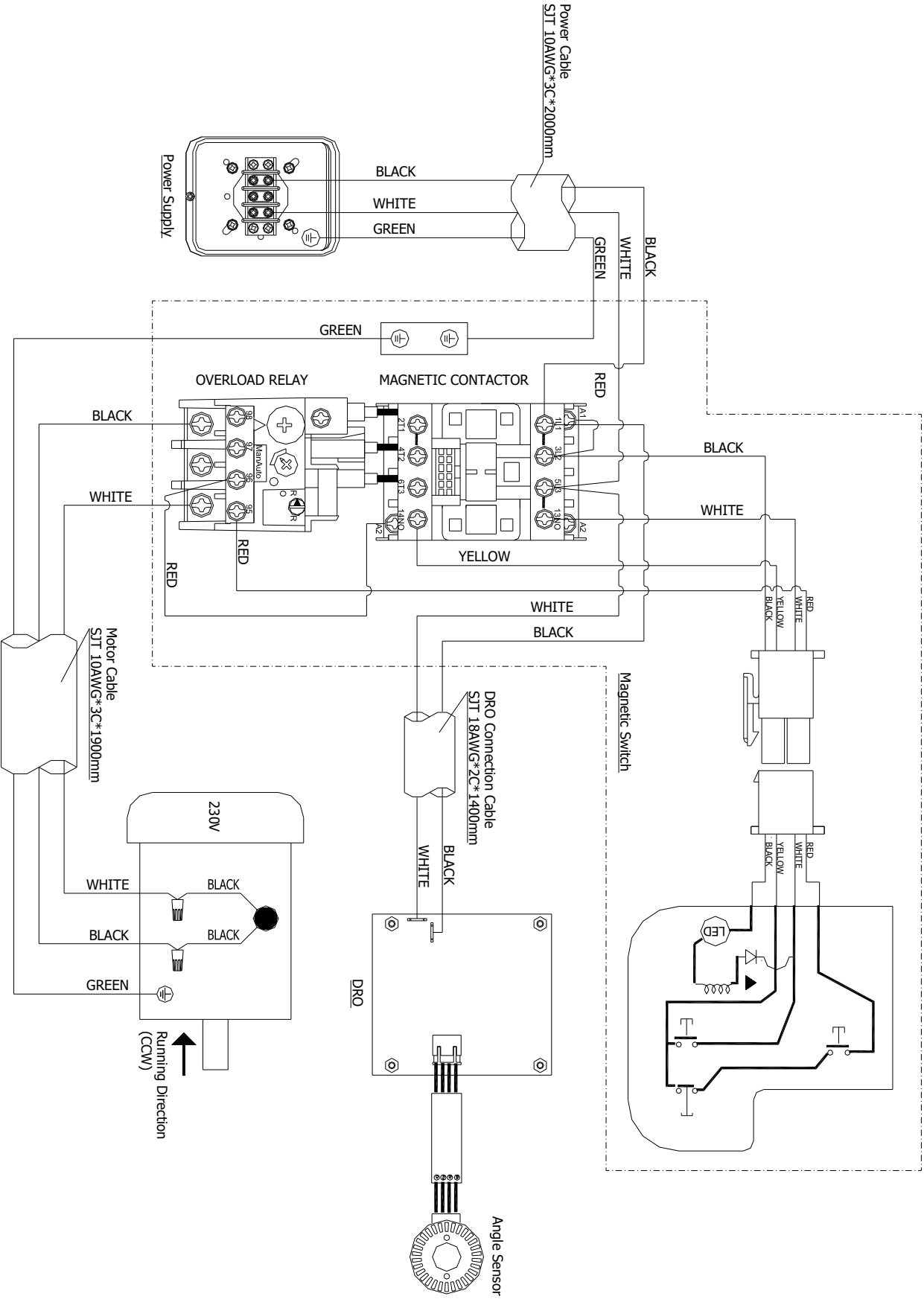

15.3 Wiring diagram – 5HP, 230V, 3PH

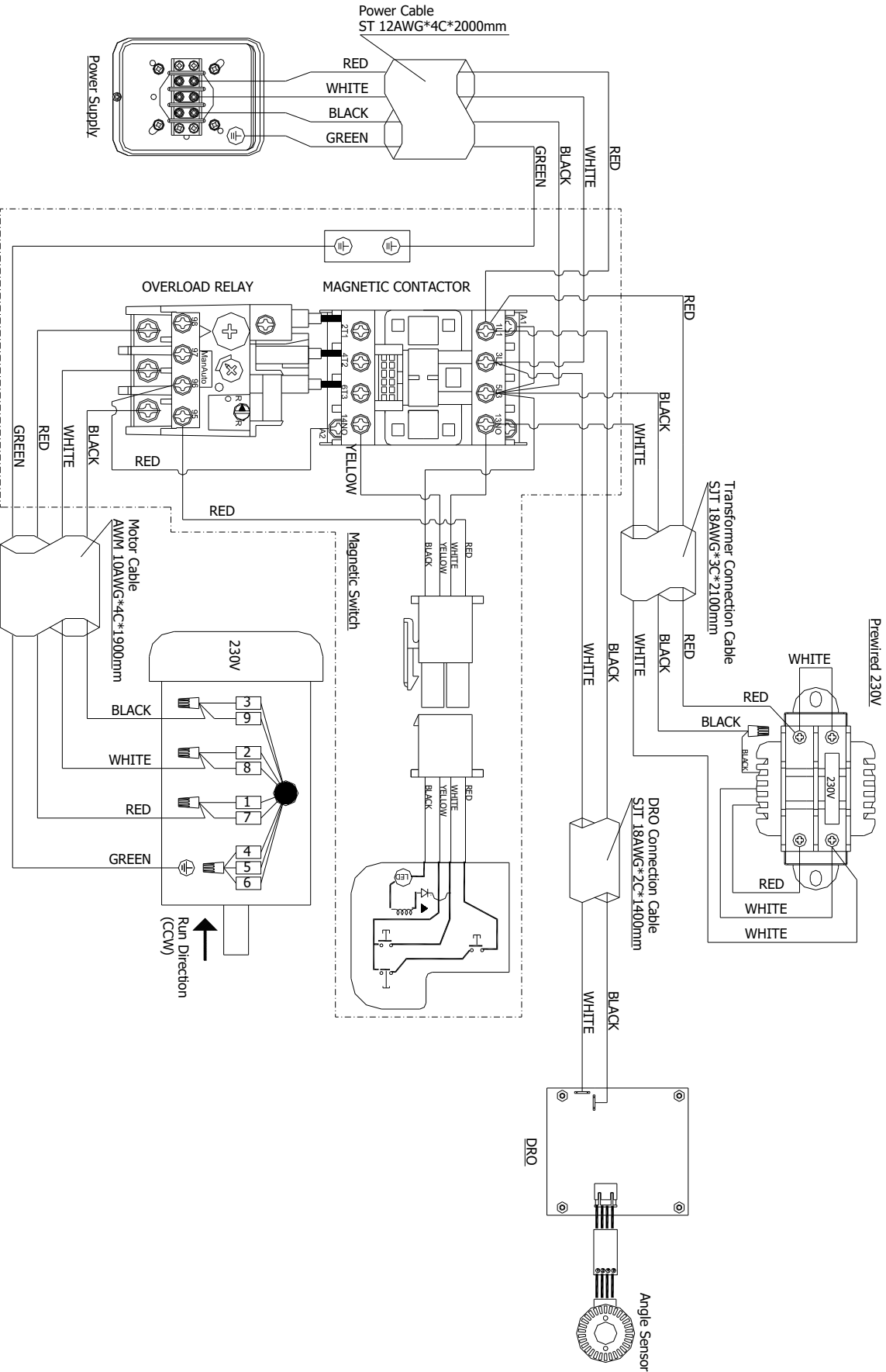

15.4 Wiring diagram – 5HP, 460V, 3PH

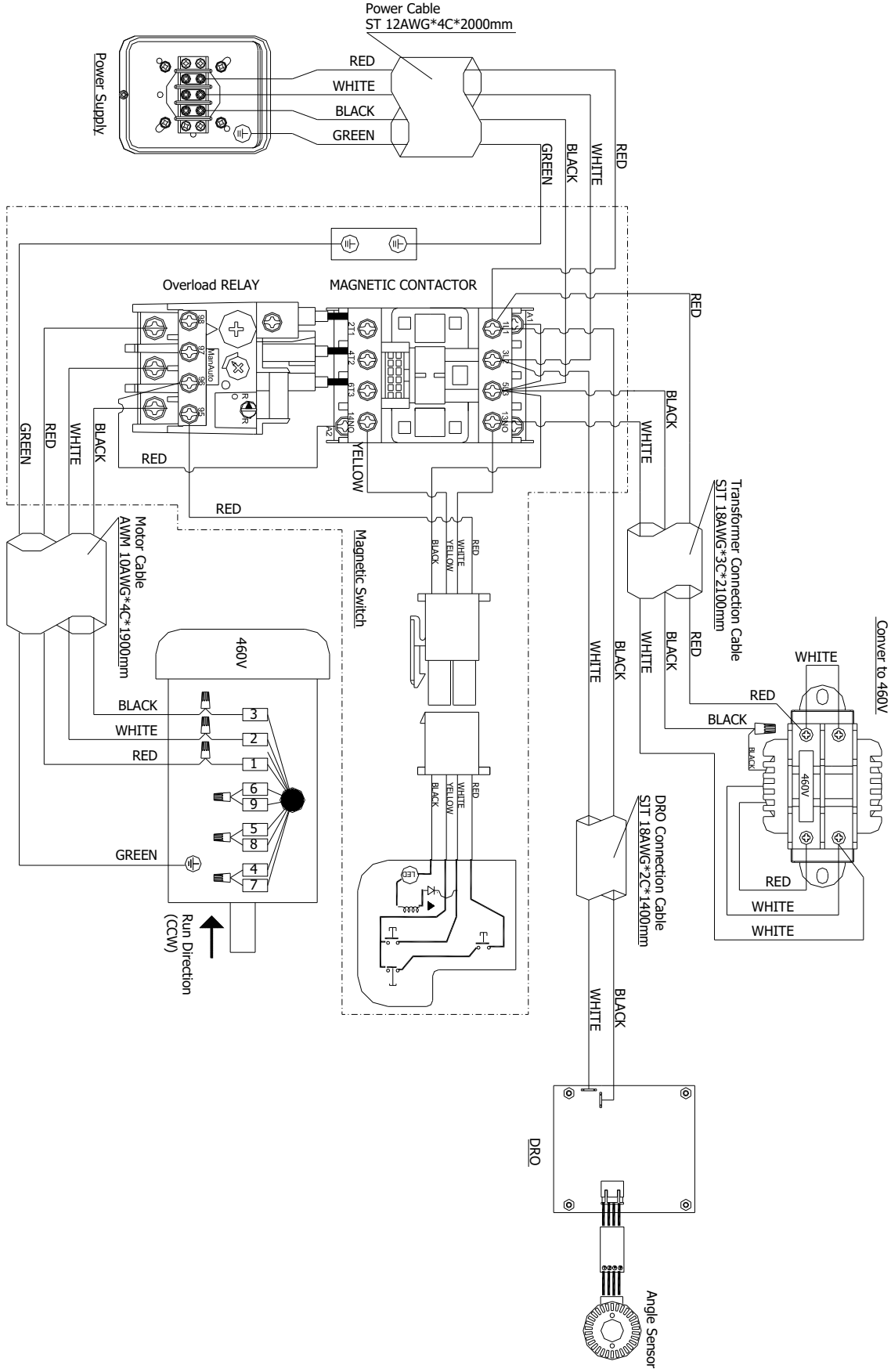

16.0 Warranty and Service

Powermatic® warrants every product it sells against manufacturers' defects. If one of our tools needs service or repair, please contact Technical Service by calling 1-800-274-6846, 8AM to 5PM CST, Monday through Friday.

Warranty Period

The general warranty lasts for the time period specified in the literature included with your product or on the official Powermatic branded website.

- Powermatic products carry a limited warranty which varies in duration based upon the product. (See chart below)
- Accessories carry a limited warranty of one year from the date of receipt.
- Consumable items are defined as expendable parts or accessories expected to become inoperable within a reasonable amount of use and are covered by a 90-day limited warranty against manufacturer's defects.

Who is Covered

This warranty covers only the initial purchaser of the product from the date of delivery.

What is Covered

This warranty covers any defects in workmanship or materials subject to the limitations stated below. This warranty does not cover failures due directly or indirectly to misuse, abuse, negligence or accidents, normal wear-and-tear, improper repair, alterations, or lack of maintenance. Powermatic woodworking machinery is designed to be used with Wood. Use of these machines in the processing of metal, plastics, or other materials outside recommended guidelines may void the warranty. The exceptions are acrylics and other natural items that are made specifically for wood turning.

Warranty Limitations

Woodworking products with a Five-Year Warranty that are used for commercial or industrial purposes default to a Two-Year Warranty. Please contact Technical Service at 1-800-274-6846 for further clarification.

How to Get Technical Support

Please contact Technical Service by calling 1-800-274-6846. **Please note that you will be asked to provide proof of initial purchase when calling.** If a product requires further inspection, the Technical Service representative will explain and assist with any additional action needed. Powermatic has Authorized Service Centers located throughout the United States. For the name of an Authorized Service Center in your area call 1-800-274-6846 or use the Service Center Locator on the Powermatic website.

More Information

Powermatic is constantly adding new products. For complete, up-to-date product information, check with your local distributor or visit the Powermatic website.

How State Law Applies

This warranty gives you specific legal rights, subject to applicable state law.

Limitations on This Warranty

POWERMATIC LIMITS ALL IMPLIED WARRANTIES TO THE PERIOD OF THE LIMITED WARRANTY FOR EACH PRODUCT. EXCEPT AS STATED HEREIN, ANY IMPLIED WARRANTIES OF MERCHANTABILITY AND FITNESS FOR A PARTICULAR PURPOSE ARE EXCLUDED. SOME STATES DO NOT ALLOW LIMITATIONS ON HOW LONG AN IMPLIED WARRANTY LASTS, SO THE ABOVE LIMITATION MAY NOT APPLY TO YOU.

POWERMATIC SHALL IN NO EVENT BE LIABLE FOR DEATH, INJURIES TO PERSONS OR PROPERTY, OR FOR INCIDENTAL, CONTINGENT, SPECIAL, OR CONSEQUENTIAL DAMAGES ARISING FROM THE USE OF OUR PRODUCTS. SOME STATES DO NOT ALLOW THE EXCLUSION OR LIMITATION OF INCIDENTAL OR CONSEQUENTIAL DAMAGES, SO THE ABOVE LIMITATION OR EXCLUSION MAY NOT APPLY TO YOU.

Powermatic sells through distributors only. The specifications listed in Powermatic printed materials and on the official Powermatic website are given as general information and are not binding. Powermatic reserves the right to effect at any time, without prior notice, those alterations to parts, fittings, and accessory equipment which they may deem necessary for any reason whatsoever.

Product Listing with Warranty Period

90 Days – Parts; Consumable items
1 Year – Motors, Machine Accessories
2 Year – Woodworking Machinery used for industrial or commercial purposes
5 Year – Woodworking Machinery

NOTE: Powermatic is a division of JPW Industries, Inc. References in this document to Powermatic also apply to JPW Industries, Inc., or any of its successors in interest to the Powermatic brand.



427 New Sanford Road
LaVergne, Tennessee 37086
Phone: 800-274-6848
www.powermatic.com